

Gear Pumps / Motors

Series PGP / PGM
Distribution program
Aluminium Designs



parker.com/pmde



ENGINEERING YOUR SUCCESS.

Contents

Contents	Page
Operating Instructions	4
1 Scope.....	4
2 Mounting instructions and hints	4
3 Commissioning	5
4 Maintenance Instructions	5
5 Trouble – shooting.....	5
6. Repairs.....	5
7 Storage	6
8 Environmental Protection.....	6
Seal Change Procedure	7
Seal Kits	8
Standard Seal Kits for pumps/motors 500 + 600	8
Direction of Rotation Change	9
Direction of Rotation	9
Dismantling the unit	9
Re-Assembling the unit.....	9
Change Direction of Rotation.....	10
Distribution Pumps PGP511	12
Distribution Pumps PGP511	13
Distribution Pumps PGP517.....	14
Distribution Pumps PGP517.....	15
Distribution Kits.....	16
SK 511M EE sealed.....	16
SK 511M EE unsealed.....	17
SK 511M J7J5 unsealed.....	18
SK 511M JJ sealed.....	19
SK 511M LL sealed.....	20
SK 511M LL unsealed.....	21
SK 517 M EE sealed.....	22
SK 517 M EE unsealed.....	23
SK 517 M J9J8 unsealed.....	24
SK 517 M LL unsealed.....	25
SK 517 M DD unsealed	26
Tandem pump unsealed between sections	27
Outboard Bearing Kits	28
S8F4, Sub-assembly (511) Part No 3911822365	28
D1L7, Sub-assembly (511) Part No 3911822471	28
K7L2, Sub-assembly (511) Part No 3911822586	29
M2L3, Sub-assembly (517) Part No 3911842243.....	29
Tandem pump exploded view	30
PGP511B...CS1D4NJ7J5S-502A...XJ4J3B1B1	30
PGP517B...CT1D7NJ9J8S-511A...NJ7J5B1B1	31
Outboard Bearing	32
Drawings.....	33
PGP502AxxxxCV2P3XE2E2B1B1	33
PGP502AxxxxCV2P3XE3E2B1B1	34
PGP502AxxxxCV2P3XJ4J3B1B1.....	35
Quick Reference Parts List.....	36-37
Shaft Loads / Fluids.....	38

1 Scope

These operating instructions apply to gear units series PGP / M 500. Any special wishes going beyond the framework of these operating instructions, need to be particularly agreed. Objections to the scope of delivery cannot be derived these operating instructions. Within the period of guarantee, it is not permitted to interfere with this pumps.

2 Mounting instructions and hints

2.1 Generals

A prerequisite for all mounting operations is cleanliness. Be careful to prevent any dirt from entering into the hydraulic system. Make sure that the inside of the piping and the fluid tank is properly cleaned.

Remove the vent plugs immediately before mounting the gear unit. Cranking the drive shaft by hand is not or hardly possible.

The mounting position is at choice. Units with 3 or 4 sections must be reinforced.

2.2 Direction of rotation.

The direction of rotation, looking at the drive shaft, clockwise, counter clockwise or double must con-form to the arrow provided on the device.

Attention! Drive pump only in indicated direction of rotation.

2.3 Couplings

2.3.1 Flexible Couplings

Flexible couplings are used for gear units with tapered or cylindrical drive shaft.

We recommend to use flexible gear rim couplings or flexible pin rim couplings.

The drive shaft must not be subjected to axial or radial loads as this would result in heavy wear of the gear unit.

The permissible deviations from the true shape and from the required position, which are shown in Fig. 1, must be complied with, according to the coupling manufacturer demands (K). If the deviations are exceeded, a reduction of the service life of the gear unit and the driving unit as whole will result.

In the event of the gear pump, the driving machine or a coupling half having been replaced, check the axial clearance E and reset it, if required.

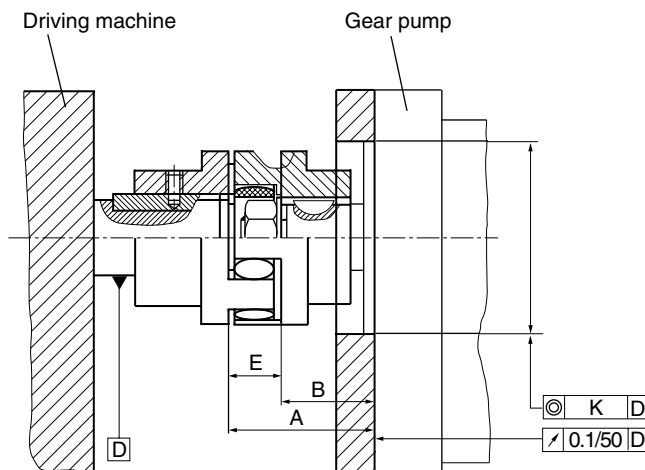

Fig. 1

2.3.2 Rigid Couplings

Rigid couplings are used for gear units with spline drive shaft.

The drive shaft must not be subjected to axial or radial loads as this would result in heavy wear of the gear unit.

The permissible deviations from the true shape and from the required position, which are shown in Fig. 2, must be complied with. Take care to ensure that the coupling is running in oil or oil mist. The external involute spline must easily enter into the splined hub.

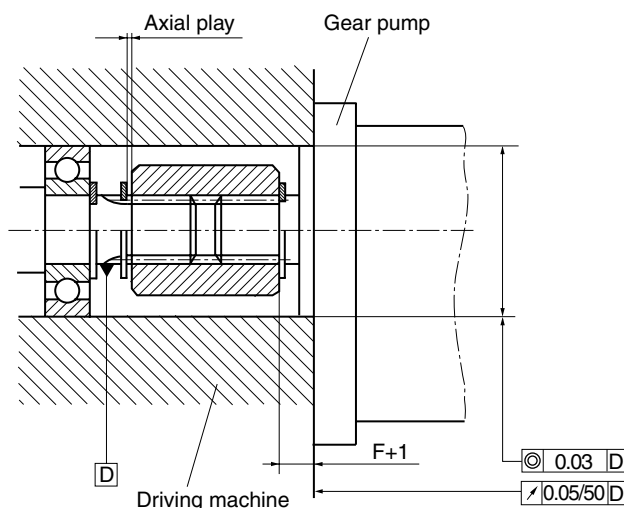

Fig. 2

2.3.3 Tang Drive

For the close – coupling of the pumps to the engines, gear boxes etc. the pump has a special tang drive which combines with a centre coupling.

2.4 Hints concerning the hydraulic system

When mounting the pipe joints, take care to ensure utmost cleanliness. Internal cleanliness - After welding, bending and fitting pipes, free them from scale, sand, corrosion and welding residuals. Scavenge the piping!

Mount the suction line such that the connection is airtight. Install the piping in vibration-free and stress-free manner.

By far the largest number of premature failures on gear pumps are due to contaminated fluid.

2.5 Filtration

Full flow filtration in the return line is always recommended. We recommend filtering which reduces the size and concentration of the contamination particles to a permitted minimum.

Rate of contamination according to:
ISO 4406 Cl. 19/17/13

2.6 Relief valve

Install the relief valve as close as possible to the gear pump. Set the operating pressure to a value exceeding the maximum operating pressure of the system by up to 10 bar.

3 Commissioning

3.1. First commissioning or after repair

- It is advisable to flush the circuit by means of a separate power pack.
- Make sure that the direction of rotation of the gear pump coincides with that of driving machine.
- Start the gear pump with opened valves only, i.e. without pressure.
- Operate the plant at a greatly reduced operating pressure.
- Vent the piping, especially when a check valve is installed in the pressure line.
- Putting into operation is considered to be completed when two filtering operations for a period of 15 minutes each do not produce any filtrate.

3.2. Commissioning after a prolonged inoperative periods

- Vent the plant
- Check the fluid

3.3 Daily putting into operation

When starting the gear unit below the service viscosity range and / or the operating temperature range, warm up the plant at a greatly reduced pressure, $p \leq 10$ bar, and reduced speed, $n \leq$ rpm.

4 Maintenance Instructions

The gear unit is maintenance free. Regular Maintenance of the hydraulic system is a prerequisite for trouble free operation of the gear pump.

Maintenance work may be done only with the plant switched off and the piping in nonpressurized condition. Be careful to ensure utmost cleanliness. Never clean filler holes hydraulic tanks and the like with fuzzy cloths. Take care to prevent any foreign matter (dirt, solvent. etc.) from entering the hydraulic circuit.

The hydraulic fluid must be renewed as the water content is ≥ 0.1 %. The maintenance of the filters depends on the conditions of the system and the regulations issued by the filter makers.

Check the coupling as to wear. Maintenance intervals depend on service conditions and shall be fixed by the users accordingly. Flexible gear rim couplings need to be prevented from any metal contact, especially when used in locations with explosive atmosphere. Maintain the electric motors according to directions issued by the manufacturer. Make sure that the piping is tight.

5 Trouble – shooting

All instructions refer to troubles caused by wear, dirt incorrect assembly or non observance of operating conditions.

6. Repairs

Repairs may be carried out only with the system switched off and the piping in none pressurized condition. Tightly close open pipe joints in order to prevent foreign matter (dirt, solvent) from entering the hydraulic system.

Change the seals according to the seal change procedure.

Type of trouble						Source of trouble
No fluid delivery	Insufficient pressure and/or volumetric flow	Strong or abnormal noise	Foaming in hydraulic tank	Fluid leakage at drive shaft	Fluid temperature to high	
x		x	x			Insufficient fluid level in hydraulic tank
x		x				Permissible input pressure value not reached
x	x	x	x			Suction line leaky
			x	x		Faulty shaft seal ring of gear pump
	x			x	x	Gear pump faulty
x		x				Coupling faulty ¹⁾
x						Wrong direction of rotation
	x	x				Relief valve incorrectly set
		x				Vibrations
	x					Piping faulty, wrong control position directional control valve
	x				x	Operating conditions (fluid temperature, viscosity, pressure duration of load application) and/or input power not in compliance with standard prospects or contract
						¹⁾ Find out and eliminate the source of trouble (wear occurring in normal operation, dirty fluid, load applied to drive shaft, operating conditions not observed)

7 Storage

Gear units are preserved for a period of 12 months. Where gear units are stored for a longer period, it is necessary to re - preserve them

Re-preserve with hydraulic oil or corrosion – inhibited oil. A removal internal preservative is not necessary.

If required, re – preserve the shaft end of the gear unit with viscous grease or a strippable anti corrosive paint.

Gear units are to be stored in dry ventilatable rooms (5 to 50 °C, relative air humidity up to 70%). Store rooms must be free from corrosion stimulating gases. Too long a storage promotes the gumming of the oil film in the interior of the unit as well as the ageing (cracking) of rubber seals.

8 Environmental Protection

Environmental Protection should be taken always into consideration when working with hydraulic liquids in a way that contamination is prevented from. Used hydraulic liquids should be disposed of in a proper way.

It is recommended that all seals are changed as matter of good practice. Units should not be dismantled any further than indicated. The arrangement of the gears and thrust blocks relative to the body determine the direction of rotation and must not be disturbed.

Procedure

Before dismantling ensure that the unit, bench and tools are thoroughly clean.

1. Where applicable withdraw the drive coupling from the drive shaft (11) using a suitable puller. The coupling must not be levered or hammered off the shaft as this will result in internal damage.
2. Remove the key (12; 13) and the wire circlip (14), (where fitted) from the drive shaft (11).
3. Lightly mark the end cover, body and mounting flange (3, 9 and 15) to ensure re-assembly in the correct position.
4. Remove bolts / screws (1), keeping the unit together stand it on the end cover (3), drive shaft (11) uppermost.
5. Remove mounting flange (15), body 'O' ring (4), back up seal (5) and seal element (6). Replace with new seals ensuring that back up seal (5) is correctly fitted.
6. Remove circlip (17) when fitted and push shaft seal/ seals (16) squarely out of the mounting flange (15) taking care not to damage any sealing surfaces. Ensure there are no burrs or scoring present in the seal bores.
7. Push shaft seal (16) squarely into the recess in the mounting flange (15) with the garter spring facing in towards the pump (on "M" and "W" coded pumps two shaft seals are fitted back to back, i.e. the inner seal is fitted garter spring inwards and the outer seal fitted with garter spring outwards). If no Loctite hydraulic sealant is used then grease must be applied to the outer diameter of the replacement seal to prevent leakage. Apply a coating of high melting point grease between the lips of the shaft seal for lubrication. The circlip (17) should be replaced.
8. Fit the shaft sleeve assembly tool (20) or, assembly sleeve supplied in seal kit, to the drive shaft (11).
9. Carefully refit the mounting flange (15) to the body (9), sliding it over the shaft sleeve tool (20) and fitting it squarely to the pins (8) and body (9).
10. Holding the whole unit together carefully turn it over, making sure it is supported on the mounting flange (15) not the shaft (11).

11. Remove the end cover (3), back up seal (5), seal element (6) and the body 'O' ring (4). Replace with new seals ensuring that back up seal (5) is correctly fitted.
12. Fit the end cover (3), taking care not to dislodge the back up seal (5) and bolt the unit together. Tighten the bolts / screws (1) to the torque figures stated below:

PGP 502	20 +3	Nm	
PGP 503	20 +3	Nm	
PGP 505	20 +3	Nm	
PGP/M 511	46 +6	Nm	
PGP 517	75 +10	Nm	screw quality 8.8
PGP 517	90 +10	Nm	screw quality 10.9

13. Pour a small amount of oil into a port and check that the shaft can be rotated without undue force using a smooth jawed hand wrench hooked around the shaft or a suitable half coupling locked against the key.
14. Where applicable, refit wire circlip (17) and key (12; 13) to the shaft.

To reorder seal kits quote code, unit number and quantity:

i.e. PGP511A0100CA1H2ND5D4B1B1 –
No.: 334 9111 061 – Seal Kit – 3 off

Standard Seal Kits for pumps/motors 500 + 600

Model Code	Pump Series	TDN
PGP502	Single	391 1832 810
	Tandem	
	Single (FPM)	391 1832 811
PGP503	Single	391 1822 170
	Tandem	391 1822 265
	Single (FPM)	391 1832 220
PGP505	Single	391 1822 101
	Tandem	391 1822 102
OPL	Single	7110-023-0NM
P11	Single	391 1822 097
	Tandem	391 1822 103
1PL	Single	7111-023-0NE
PGP511	Single	8611-023-00N
	Single (Large size shaft)	8611-023-Q1N
	Single (FPM)	8611-023-00V
	Triple (FPM unsealed)	391 1832 770
	Tandem	8677-023-0NE
	Tandem rear	8677-023-000
	Triple PGP511	8832-023-0NX
	Tandem (sealed section)	3911832766
("S8F4")	Pump with outboard bearing	3911832133
PGP511S	Split gear	8801-023-00N
	Split gear (Large size sh.)	8801-023-Q1N
	Split gear (FPM)	8801-023-00V
	Split gear tandem rear	8850-023-000
PGP517	Single	391 1822 071
	Single (FPM)	391 1832 772
	Tandem	391 1822 072
	Triple	391 1822 073
	FPM 517/517/511/511	391 1832 772
PGP517 / PGP505	Tandem	391 1822 254
PGP517 / PGP511	Tandem	391 1822 531
1PR	Single	3911832656
2PX	Single	8676-023-00N
2PL	Single	7112-023-0NY
3PL	Single	7113-023-0N0

Model Code	Motor Series	TDN
PGM502	Motor BI-ROT	391 1832 812
PGM503	Motor UNI-ROT	391 1822 170
PGM505	Motor UNI-ROT	391 1822 101
	Motor BI-ROT	391 1801 304
M11	Motor UNI-ROT	391 1822 097
M11	Motor BI-ROT	3911801311
M11 + Bearing	Motor BI-ROT + Bearing	3911801340
PGM511	Motor (Bi + Uni-Rot.)	8301-023-00N
	Motor (large size shaft)	8301-023-Q1M
("S2F3", "S8F4")	Motor with outboard bearing	3911832704
	Motor with plain bearing	8772-023-00S
	Motor (FPM)	8301-023-00M
	Motor FPM (large shaft)	3911832086
	Motor FPM with bearing	3911832087
PGM517	Motor UNI-ROT	3911801335
	Motor UNI-ROT FPM	3911801410
	Motor BI-ROT	3911801336

SERIES 600	Pump Series	TDN
PGP620	Single	8682-023-00N
	Tandem rear	8833-023-000
	Tandem	4070H-023-000
	Tandem (FPM)	3911822474
	Single (FPM)	8682-023-00V
	Triple Pump	3911832610
PGP620	...T2K5...	3911832635
PGP620/PGP511	Tandem	8766-023-00N
PGP620/PGP511	Tandem (FPM)	8766-023-00V
PGP620/ PGP511/511	Triple (sealed)	3911832720
PGP620/620/ PGP511	Triple (FPM)	3911832716
PGP640	Single	3911832598
PGP640	Single (FPM)	3911832611
PGP640	Tandem (M)	3911832696
PGP640/PGP511	Tandem (M)	3911832798
PGP640/620/620	Triple Pump	3911832468

Direction of Rotation

The direction of rotation is indicated by an arrow etched on the body adjacent to the drive shaft. Rotation is always specified as viewed on the drive shaft

Dismantling the unit

Before starting work ensure that the unit, work area and all tools are thoroughly clean to prevent contaminant entering the unit.

1. Withdraw drive coupling from the drive shaft using a suitable puller. The coupling must not be levered or hammered off the shaft as this will result in internal damage.
2. Remove key (12, 13) and wire circlip (14), where fitted, from the drive shaft (11).
3. Lightly mark the end cover, body and mounting flange (3, 9 and 15) to ensure re-assembly in the correct position.
4. Stand the unit on the mounting flange (15), drive shaft down most in a suitable fixture. Remove the bolts / screws and spring washers (1;2).
5. Remove the end cover (3).
6. Slide the Housing (9) squarely off the drive shaft (11).
7. Remove the upper thrust block (7), drive shaft (11), driven gear (10). Remove the below thrust block. Keep the mounting flange (15) in this position.

4. Carefully refit the housing (9) 180° turned, the pins facing the mounting flange (15). Make sure that the Inlet side from housing and thrust block (9, 7) are in the right position and the “O”-ring (4) is correctly fitted. See Fig. 3.
5. Fit end cover (3), taking care not to dislodge the back up seal (5), seal element (6) and body “O” ring (4) and bolt the unit together. Tighten the bolts / screws (1) to the torque figures stated below:

PGP 502	20 +3	Nm	
PGP 503	20 +3	Nm	
PGP 505	20 +3	Nm	
PGP/M 511	46 +6	Nm	
PGP 517	75 +10	Nm	screw quality 8.8
PGP 517	90 +10	Nm	screw quality 10.9
6. Pour a small amount of hydraulic oil into the inlet port and check that the drive shaft can be rotated.
7. Where applicable, refit wire circlip (17) and key (12, 13) to the shaft.

Re-Assembling the unit

Ensure all parts are perfectly clean and lubricate bushes and gears with clean hydraulic fluid (ensure ‘O’ ring recess and end faces of body remain dry). This will assist assembly of components into the body bores.

1. Fit the thrust block (7) 180° turned on the mounting flange, the seals (5, 6) facing to the mounting flange (15)
2. Refit the drive shaft and the driven gear (11,10) and. Fit the other thrust block (7) 180° turned on the shafts. Fit the sleeve assembly tool or the assembly sleeve (20,21) to the drive shaft (11).
3. Fit the thrust blocks (7) and the gears (10,11) with the assembly sleeve (20) to the mounting flange (15). Make sure that the seals are upper-most. See Fig. 2. Remove the assembly tool

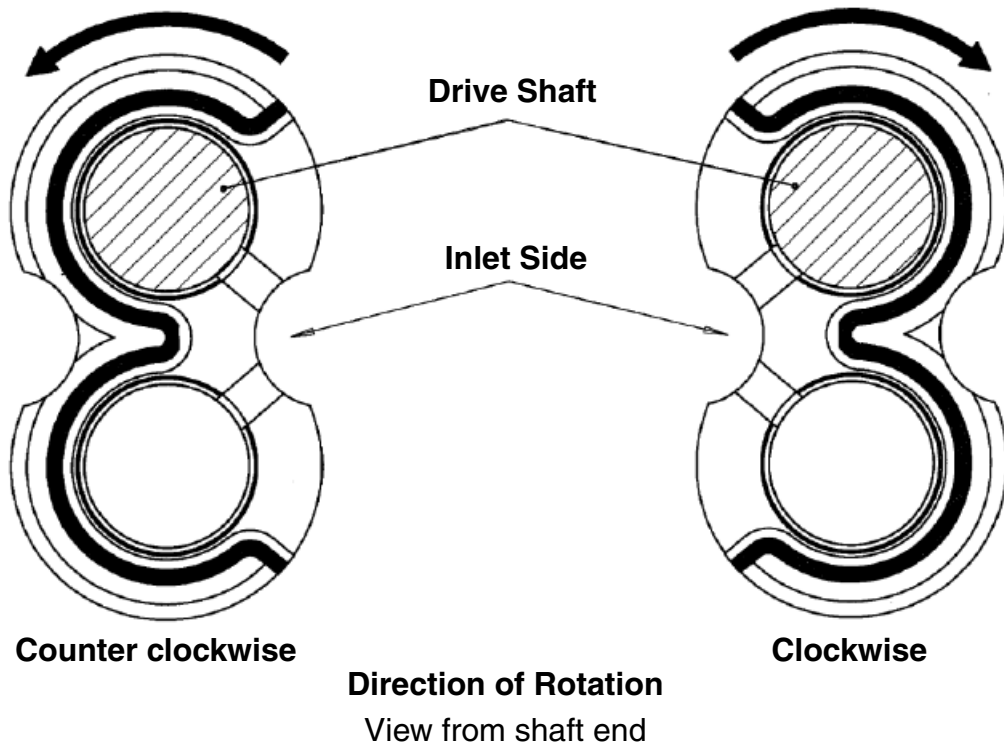
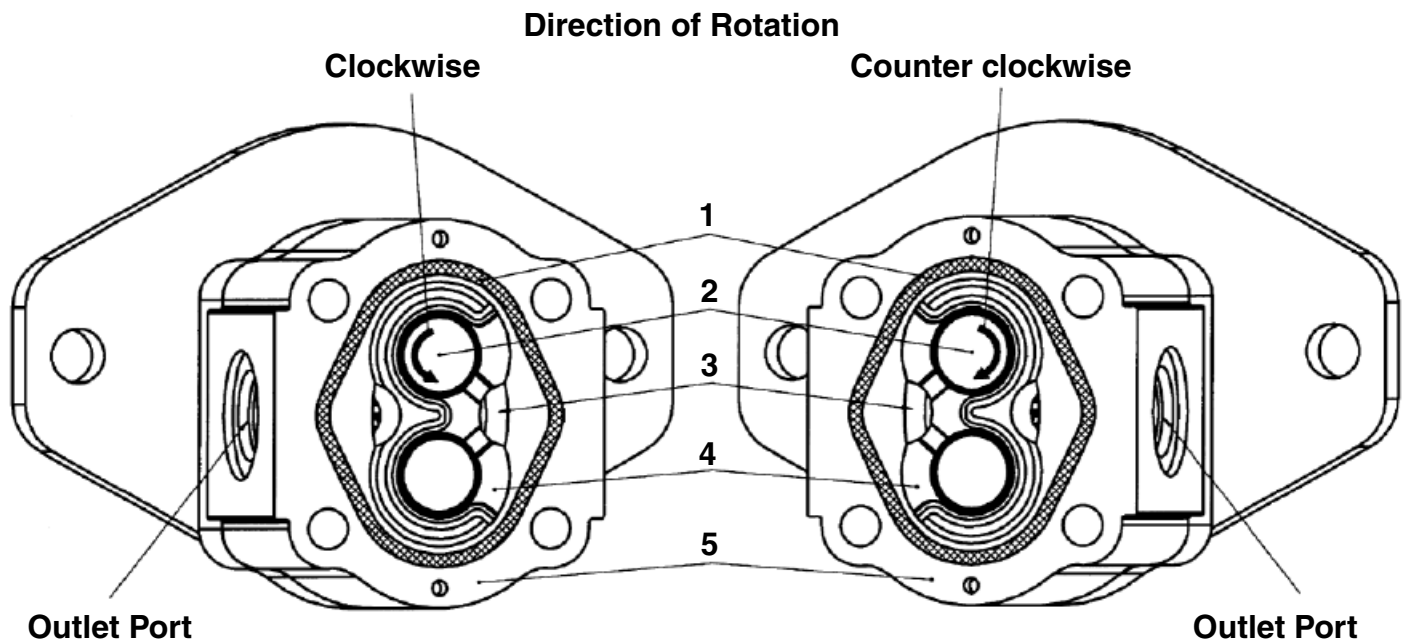

Fig 1



1. Body "O"-ring
2. Drive Shaft
3. Inlet Side
4. Thrust Block
5. Housing

Fig 2

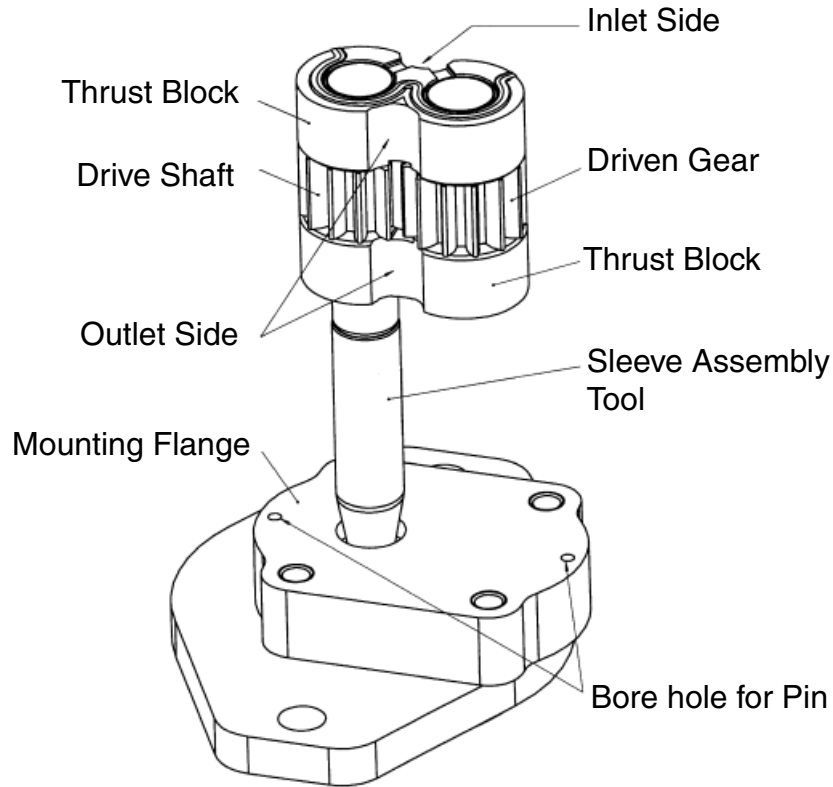
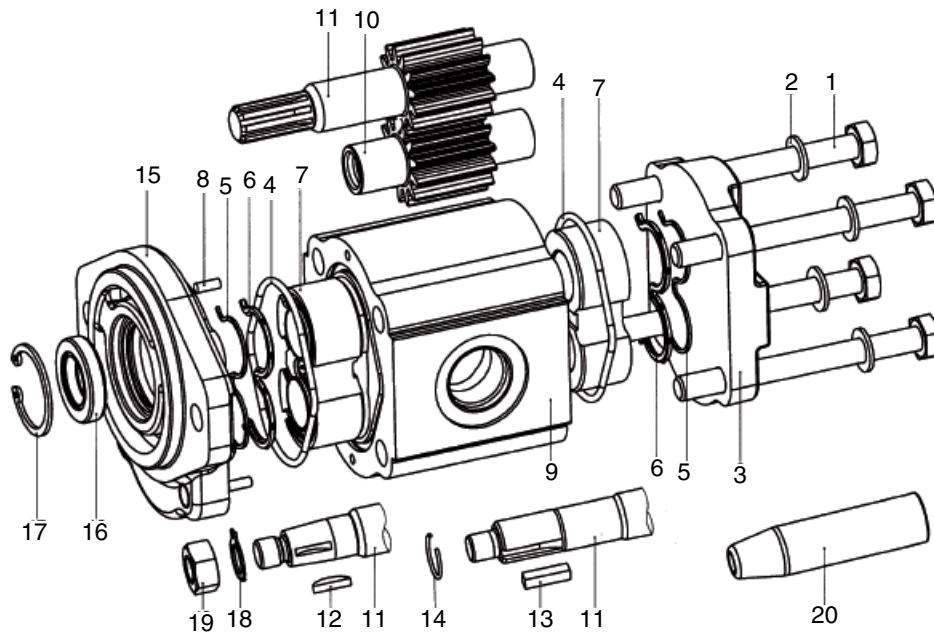
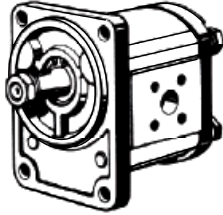
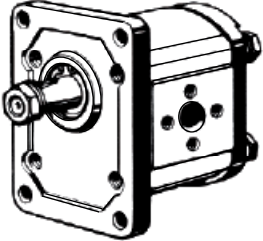
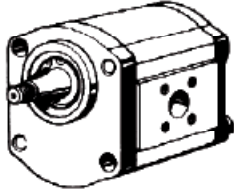
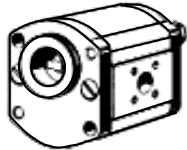

Fig 3



No.:	Description
1	Screw / Bolt
2	Spring washer
3	End cover
4	Body O – ring
5	Back up seal
6	Seal element
7	Thrust block
8	Pin
9	Body
10	Driven Gear

No.:	Description
11	Drive shaft
12	Woodruff key
13	Square key
14	Circlip
15	Mounting flange
16	Shaft seal
17	Circlip
18	Tab washer
19	Nut
20	Sleeve assembly tool

CODE	Partnumber	Rotation	Description	
All Pumps with internal spline for assembly of multiple sections				
PGP511M0060CS1D4NJ7J5B1B1	334 9111 336	cw	Ø80 6cc taper 1:5	
PGP511M0080CS1D4NJ7J5B1B1	334 9111 337	cw	Ø80 8cc taper 1:5	
PGP511M0110CS1D4NJ7J5B1B1	334 9111 328	cw	Ø80 11cc taper 1:5	
PGP511M0140CS1D4NJ7J5B1B1	334 9111 329	cw	Ø80 14cc taper 1:5	
PGP511M0160CS1D4NJ7J5B1B1	334 9111 332	cw	Ø80 16cc taper 1:5	
PGP511M0190CS1D4NJ7J5B1B1	334 9111 333	cw	Ø80 19cc taper 1:5	
PGP511M0230CS1D4NJ7J5B1B1	334 9111 334	cw	Ø80 23cc taper 1:5	
PGP511M0330CS1D4NJ7J5B1B1	334 9111 331	cw	Ø80 33cc taper 1:5	
PGP511M0040CS2D3NL1L1B1B1	334 9111 356	cw	Ø36,5 4cc taper 1:8	
PGP511M0060CS2D3NL1L1B1B1	334 9111 357	cw	Ø36,5 6cc taper 1:8	
PGP511M0080CS2D3NL1L1B1B1	334 9111 358	cw	Ø36,5 8cc taper 1:8	
PGP511M0100CS2D3NL2L1B1B1	334 9116 008	cw	Ø36,5 11cc taper 1:8	
PGP511M0110CS2D3NL2L1B1B1	334 9111 360	cw	Ø36,5 11cc taper 1:8	
PGP511M0140CS2D3NL2L1B1B1	334 9111 484	cw	Ø36,5 14cc taper 1:8	
PGP511M0160CS2D3NL2L1B1B1	334 9111 361	cw	Ø36,5 16cc taper 1:8	
PGP511M0190CS2D3NL2L1B1B1	334 9111 362	cw	Ø36,5 19cc taper 1:8	
PGP511M0230CS2D3NL2L1B1B1	334 9111 363	cw	Ø36,5 23cc taper 1:8	
PGP511M0270CS2D3NL2L1B1B1	334 9111 364	cw	Ø36,5 27cc taper 1:8	
PGP511M0310CS2D3NL2L1B1B1	334 9111 565	cw	Ø36,5 31cc taper 1:8	
PGP511M0330CS2D3NL2L1B1B1	334 9111 566	cw	Ø36,5 33cc taper 1:8	
PGP511M0040CS1Q4NJ7J5B1B1	3349111545	cw	Ø50 4cc taper 1:5	
PGP511M0060CS1Q4NJ7J5B1B1	3349111338	cw	Ø50 6cc taper 1:5	
PGP511M0080CS1Q4NJ7J5B1B1	3349111339	cw	Ø50 8cc taper 1:5	
PGP511M0110CS1Q4NJ7J5B1B1	3349111341	cw	Ø50 11cc taper 1:5	
PGP511M0140CS1Q4NJ7J5B1B1	3349111342	cw	Ø50 14cc taper 1:5	
PGP511M0160CS1Q4NJ7J5B1B1	3349111343	cw	Ø50 16cc taper 1:5	
PGP511M0190CS1Q4NJ7J5B1B1	3349111344	cw	Ø50 19cc taper 1:5	
PGP511M0230CS1Q4NJ7J5B1B1	3349111345	cw	Ø50 23cc taper 1:5	
PGP511M0270CS1Q4NJ7J5B1B1	3349111346	cw	Ø50 27cc taper 1:5	
PGP511M0040AS1Q4NJ7J5B1B1	3349112280	ccw	Ø50 4cc taper 1:5	
PGP511M0060AS1Q4NJ7J5B1B1	3349112175	ccw	Ø50 6cc taper 1:5	
PGP511M0080AS1Q4NJ7J5B1B1	3349112176	ccw	Ø50 8cc taper 1:5	
PGP511M0110AS1Q4NJ7J5B1B1	3349112178	ccw	Ø50 11cc taper 1:5	
PGP511M0140AS1Q4NJ7J5B1B1	3349112179	ccw	Ø50 14cc taper 1:5	
PGP511M0160AS1Q4NJ7J5B1B1	3349112180	ccw	Ø50 16cc taper 1:5	
PGP511M0190AS1Q4NJ7J5B1B1	3349112181	ccw	Ø50 19cc taper 1:5	
PGP511M0230AS1Q4NJ7J5B1B1	3349112182	ccw	Ø50 23cc taper 1:5	
PGP511M0270AS1Q4NJ7J5B1B1	3349112183	ccw	Ø50 27cc taper 1:5	
PGP511M0040CV5Q3XJ7J5B1B1	3349111350	cw	Ø50 4cc taper 1:5	
PGP511M0060CV5Q3XJ7J5B1B1	3349111351	cw	Ø50 6cc taper 1:5	
PGP511M0080CV5Q3XJ7J5B1B1	3349111352	cw	Ø50 8cc taper 1:5	
PGP511M0110CV5Q3XJ7J5B1B1	3349116094	cw	Ø50 11cc taper 1:5	
PGP511M0140CV5Q3XJ7J5B1B1	3349116059	cw	Ø50 14cc taper 1:5	
PGP511M0160CV5Q3XJ7J5B1B1	3349111299	cw	Ø50 16cc taper 1:5	
PGP511M0190CV5Q3XJ7J5B1B1	3349116077	cw	Ø50 19cc taper 1:5	
PGP511M0230CV5Q3XJ7J5B1B1	3349116078	cw	Ø50 23cc taper 1:5	
PGP511M0040AV5Q3XJ7J5B1B1	3349112184	ccw	Ø52 4cc taper 1:5	
PGP511M0060AV5Q3XJ7J5B1B1	3349112185	ccw	Ø52 6cc taper 1:5	
PGP511M0160AV5Q3XJ7J5B1B1	3349112521	ccw	Ø52 16cc taper 1:5	
PGP511M0230AV5Q3XJ7J5B1B1	3349112522	ccw	Ø52 23cc taper 1:5	

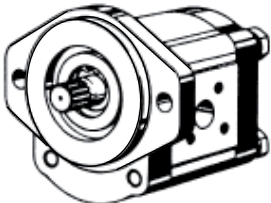
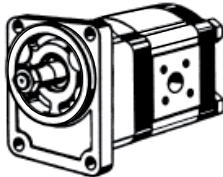
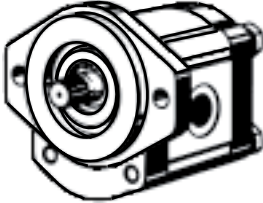
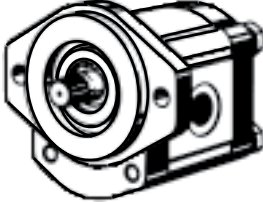
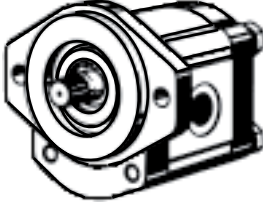
CODE	Partnumber	Rotation	Description	
All Pumps with internal spline for assembly of multiple sections				
PGP511M0060CA1H2NJ7J5B1B1	3349111411	cw	Ø82,55 6cc SAE-A 9T	
PGP511M0080CA1H2NJ7J5B1B1	3349111772	cw	Ø82,55 8cc SAE-A 9T	
PGP511M0110CA1H2NJ7J5B1B1	3349111483	cw	Ø82,55 11cc SAE-A 9T	
PGP511M0140CA1H2NJ7J5B1B1	3349111773	cw	Ø82,55 14cc SAE-A 9T	
PGP511M0160CA1H2NJ7J5B1B1	3349111774	cw	Ø82,55 16cc SAE-A 9T	
PGP511M0190CA1H2NJ7J5B1B1	3349111775	cw	Ø82,55 19cc SAE-A 9T	
PGP511M0230CA1H2NJ7J5B1B1	3349111776	cw	Ø82,55 23cc SAE-A 9T	
PGP511M0270CA1H2NJ7J5B1B1	3349111805	cw	Ø82,55 27cc SAE-A 9T	
PGP511M0040AA1H2NJ7J5B1B1	3349112734	ccw	Ø82,55 4cc SAE-A 9Z	
PGP511M0060AA1H2NJ7J5B1B1	3349112285	ccw	Ø82,55 6cc SAE-A 9Z	
PGP511M0080AA1H2NJ7J5B1B1	3349112284	ccw	Ø82,55 8cc SAE-A 9Z	
PGP511A0080CS8F4NJ7J5B1B1	3349114025	cw	Ø80 8cc taper 1:5	
PGP511A0110CS8F4NJ7J5B1B1	3349114056	cw	Ø80 11cc taper 1:5	
PGP511A0160CS8F4NJ7J5B1B1	3349114065	cw	Ø80 16cc taper 1:5	
PGP511M0060CA1H2NE5E3B1B1	3349116451	ccw	Ø82,5 6cc SAE-A 9T	
PGP511M0080CA1H2NE5E3B1B1	3349116452	ccw	Ø82,5 8cc SAE-A 9T	
PGP511M0100CA1H2NE5E3B1B1	3349116454	ccw	Ø82,5 10cc SAE-A 9T	
PGP511M0110CA1H2NE5E3B1B1	3349116456	ccw	Ø82,5 11cc SAE-A 9T	
PGP511M0160CA1H2NE5E3B1B1	3349116458	ccw	Ø82,5 16cc SAE-A 9T	
PGP511M0040CK1H2ND4D3B1B1	3349116034	cw	Ø82,5 4 cc SAE-A Keyed	
PGP511M0060CK1H2ND5D4B1B1	3349116035	cw	Ø82,5 6 cc SAE-A Keyed	
PGP511M0080CK1H2ND5D4B1B1	3349116036	cw	Ø82,5 8 cc SAE-A Keyed	
PGP511M0110CK1H2ND6D5B1B1	3349116031	cw	Ø82,5 11 cc SAE-A Keyed	
PGP511M0140CK1H2ND6D5B1B1	3349116032	cw	Ø82,5 14 cc SAE-A Keyed	
PGP511M0160CK1H2ND6D5B1B1	3349116033	cw	Ø82,5 16 cc SAE-A Keyed	
PGP511M0190CK1H2ND6D5B1B1	3349116473	cw	Ø82,5 19 cc SAE-A Keyed	
PGP511M0230CK1H2ND7D6B1B1	3349116038	cw	Ø82,5 23 cc SAE-A Keyed	
PGP511M0270CK1H2ND7D6B1B1	3349116039	cw	Ø82,5 27 cc SAE-A Keyed	
PGP511M0040CA1H2MD4D3B1B1	3349111578	cw	Ø82,5 4 cc SAE-A 9T	
PGP511M0060CA1H2MD5D4B1B1	3349111579	cw	Ø82,5 6 cc SAE-A 9T	
PGP511M0080CA1H2MD5D4B1B1	3349111580	cw	Ø82,5 8 cc SAE-A 9T	
PGP511M0110CA1H2MD6D5B1B1	3349111582	cw	Ø82,5 11 cc SAE-A 9T	
PGP511M0140CA1H2MD6D5B1B1	3349111583	cw	Ø82,5 14 cc SAE-A 9T	
PGP511M0160CA1H2MD6D5B1B1	3349111584	cw	Ø82,5 16 cc SAE-A 9T	
PGP511M0190CA1H2MD7D6B1B1	3349111585	cw	Ø82,5 19 cc SAE-A 9T	
PGP511M0230CA1H2MD7D6B1B1	3349111586	cw	Ø82,5 23 cc SAE-A 9T	
PGP511M0270CA1H2MD7D6B1B1	3349111587	cw	Ø82,5 27 cc SAE-A 9T	

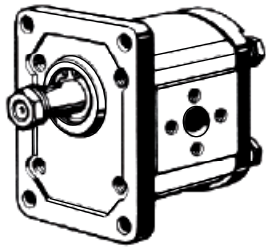
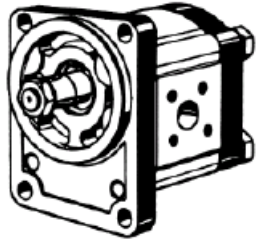
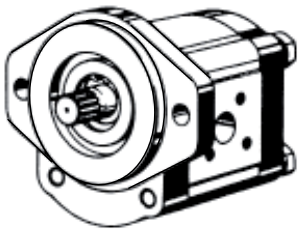
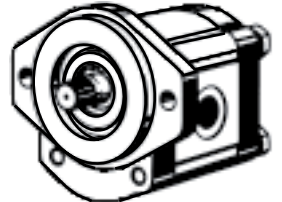
CODE	Partnumber	Rotation	Description	
All Pumps with internal spline for assembly of multiple sections				
PGP517M0140CT1D7NL3L2B1B1	3339111326	cw	Ø50,77 14cc CONE1:8	
PGP517M0160CT1D7NL3L2B1B1	3339111327	cw	Ø50,77 16cc CONE1:8	
PGP517M0190CT1D7NL3L2B1B1	3339111328	cw	Ø50,77 19cc CONE1:8	
PGP517M0230CT1D7NL3L2B1B1	3339111329	cw	Ø50,77 23cc CONE1:8	
PGP517M0250CT1D7NL3L2B1B1	3339111330	cw	Ø50,77 25cc CONE1:8	
PGP517M0280CT1D7NL3L2B1B1	3339111331	cw	Ø50,77 28cc CONE1:8	
PGP517M0330CT1D7NL3L2B1B1	3339111332	cw	Ø50,77 33cc CONE1:8	
PGP517M0380CT1D7NL3L2B1B1	3339111334	cw	Ø50,77 38cc CONE1:8	
PGP517M0440CT1D7NL3L2B1B1	3339111335	cw	Ø50,77 44cc CONE1:8	
PGP517M0520CT1D7NL3L2B1B1	3339111336	cw	Ø50,77 52cc CONE1:8	
PGP517M0580CT1D7NL3L3B1B1	3339111337	cw	Ø50,77 58cc CONE1:8	
PGP517M0700CT1D7NL3L3B1B1	3339111325	cw	Ø50,77 70cc CONE1:8	
PGP517M0230CT2D6NJ9J8B1B1	3339111266	cw	Ø80 23cc CONE1:5	
PGP517M0250CT2D6NJ9J8B1B1	3339111596	cw	Ø80 25cc CONE1:5	
PGP517M0280CT2D6NJ9J8B1B1	3339111194	cw	Ø80 28cc CONE1:5	
PGP517M0330CT2D6NJ9J8B1B1	3339111597	cw	Ø80 33cc CONE1:5	
PGP517M0380CT2D6NJ9J8B1B1	3339111418	cw	Ø80 38cc CONE1:5	
PGP517M0440CT2D6NJ9J8B1B1	3339111598	cw	Ø80 44cc CONE1:5	
PGP517M0520CT2D6NJ9J8B1B1	3339111599	cw	Ø80 52cc CONE1:5	
PGP517M0190CD1H3NJ9J8B1B1	3339111676	cw	Ø101,6 19cc SAE-B 13T	
PGP517M0380CD1H3NJ9J8B1B1	3339111161	cw	Ø101,6 38cc SAE-B 13T	
PGP517M0440CD1H3NJ9J8B1B1	3339111419	cw	Ø101,6 44cc SAE-B 13T	
PGP517M0520CD1H3NJ9J8B1B1	3339111420	cw	Ø101,6 52cc SAE-B 13T	
PGP517M0230AD1H3NJ9J8B1B1	3339112413	ccw	Ø101,6 23cc SAE-B 13T	
PGP517M0280AD1H3NJ9J8B1B1	3339112320	ccw	Ø101,6 28cc SAE-B 13T	
PGP517M0330AD1H3NJ9J8B1B1	3339112206	ccw	Ø101,6 33cc SAE-B 13T	
PGP517M0380AD1H3NJ9J8B1B1	3339112243	ccw	Ø101,6 38cc SAE-B 13T	
PGP517M0440AD1H3NJ9J8B1B1	3339112207	ccw	Ø101,6 44cc SAE-B 13T	
PGP517M0230AD1H3NE7E6B1B1	3339112407	ccw	Ø101,6 23cc SAE-B 13T	
PGP517M0280AD1H3NE7E6B1B1	3339112405	ccw	Ø101,6 28cc SAE-B 13T	
PGP517M0330AD1K6NE7E6B1B1	3339112442	ccw	Ø101,6 33cc SAE-B 13T	
PGP517M0380AD1K6NE7E6B1B1	3339112443	ccw	Ø101,6 38cc SAE-B 13T	
PGP517M0440AD1K6NE8E6B1B1	3339112444	ccw	Ø101,6 44cc SAE-B 13T	
PGP517M0520AD1H3NE8E6B1B1	3339112402	ccw	Ø101,6 52cc SAE-B 13T	

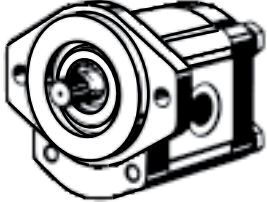
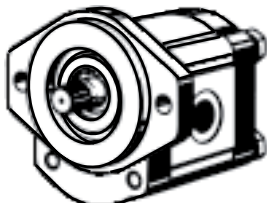
CODE	Partnumber	Rotation	Description	
All Pumps with internal spline for assembly of multiple sections				
PGP517M0230CD1H3ND6D5B1B1	3339111527	cw	O101,6 23cc SAE-B 13T	
PGP517M0250CD1H3ND6D5B1B1	3339111528	cw	O101,6 25cc SAE-B 13T	
PGP517M0280CD1H3ND7D5B1B1	3339111529	cw	O101,6 28cc SAE-B 13T	
PGP517M0330CD1H3ND7D5B1B1	3339111530	cw	O101,6 33cc SAE-B 13T	
PGP517M0380CD1H3ND7D6B1B1	3339111531	cw	O101,6 38cc SAE-B 13T	
PGP517M0440CD1H3ND7D6B1B1	3339111532	cw	O101,6 44cc SAE-B 13T	
PGP517M0520CD1H3ND7D6B1B1	3339111533	cw	O101,6 52cc SAE-B 13T	
PGP517M0580CD1H3ND8D6B1B1	3339111810	cw	O101,6 58cc SAE-B 13T	
PGP517M0700CD1H3ND8D7B1B1	3339111534	cw	O101,6 70cc SAE-B 13T	
PGP517M0230CM1H3ND6D5B1B1	3339111802	cw	O101,6 23cc SAE-B keyed	
PGP517M0280CM1H3ND7D5B1B1	3339111803	cw	O101,6 28cc SAE-B keyed	
PGP517M0330CM1H3ND7D5B1B1	3339111804	cw	O101,6 33cc SAE-B keyed	
PGP517M0380CM1H3ND7D6B1B1	3339111805	cw	O101,6 38cc SAE-B keyed	
PGP517M0440CM1H3ND7D6B1B1	3339111806	cw	O101,6 44cc SAE-B keyed	
PGP517M0520CM1H3ND7D6B1B1	3339111807	cw	O101,6 52cc SAE-B keyed	
PGP517M0580CM1H3ND8D6B1B1	3339111809	cw	O101,6 58cc SAE-B keyed	
PGP517M0700CM1H3ND8D7B1B1	3339111808	cw	O101,6 70cc SAE-B keyed	

SK 511M EE sealed

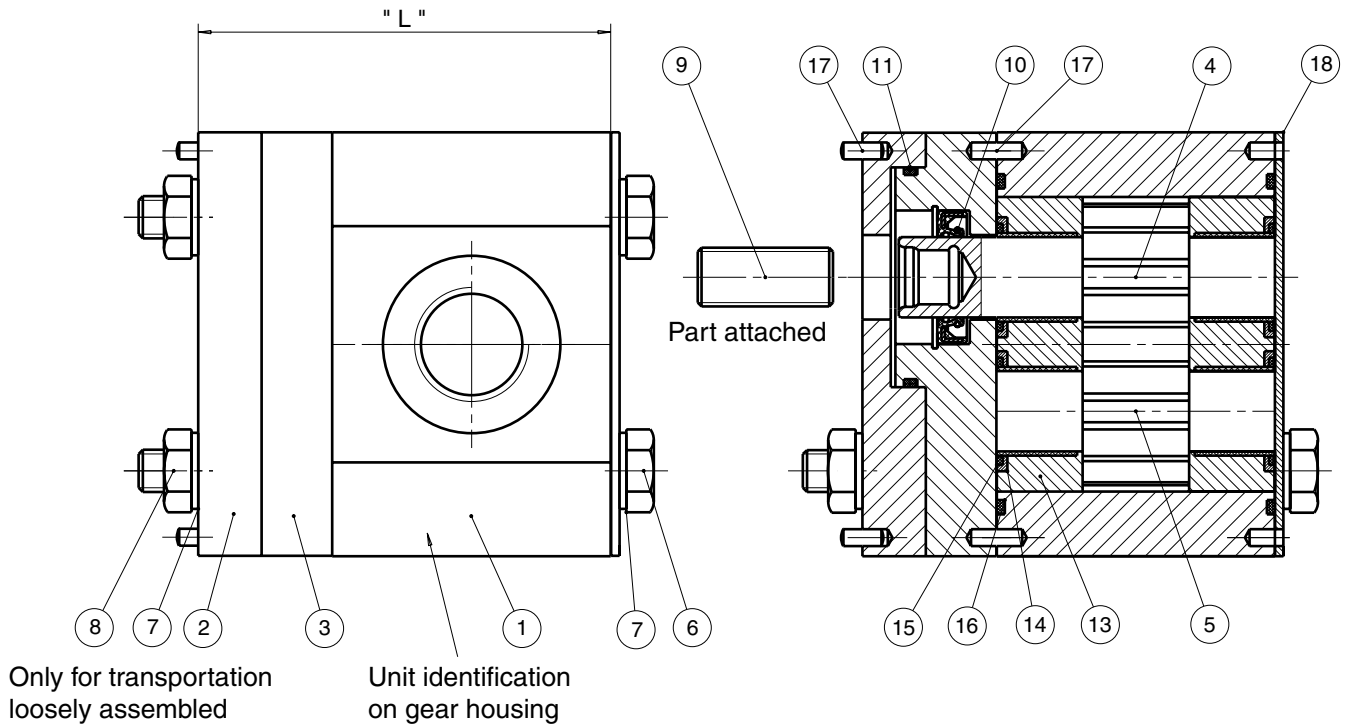

Item	Part No	Required	Description
1	See table	1	Gear housing
2	3345050204	1	PEC housing.
3	3345051205	1	SEC housing
4	See table	1	Drive gear
5	See table	1	Driven gear
6	See table	2	Screw
7	3913782231	4	Washer
8	3911451167	2	Nut
9	3321133001	1	Conn. shaft
10	9352-061-00T	1	Lip seal
11	3912882187	1	O-ring
12	9211-325-003	1	Snap ring
13	8898-207-00U	2	Thr. block
14	8611-016-00R	2	Chan. seal
15	8611-015-000	2	BK-up seal
16	9313-145-00B	2	Sect. seal
17	3912080078	4	Dowel pin
18	73910:4046745	1	Cover plate

Unit to be break-in with special test equipment
 Direktion: Clockwise
 Pressure: 210 bar

Code	Kit No.	Gear housing 1x	Drive gear 1x	Driven gear 1x	Screw 2 x over cross	Dim. "L"
KIT, SERV=S-511M0040NE3E2	3911822720	3348104925	3342604004	3342704000	3911401544	78.8
KIT, SERV=S-511M0060NE5E3	3911822721	3348106406	3342606004	3342706000	3911401544	81.9
KIT, SERV=S-511M0080NE5E3	3911822722	3348108406	3342608004	3342708000	3911401545	85.1
KIT, SERV=S-511M0100NE5E3	3911822723	3348110406	3342610004	3342710000	3911401545	88.3
KIT, SERV=S-511M0110NE5E3	3911822724	3348111406	3342611004	3342711000	3911401546	89.8
KIT, SERV=S-511M0140NE6E5	3911822725	3348114418	3342614004	3342714000	3911401547	94.6
KIT, SERV=S-511M0160NE6E5	3911822726	3348116418	3342616004	3342716000	3911401547	97.7
KIT, SERV=S-511M0190NE6E5	3911822727	3348119418	3342619004	3342719000	3911401548	102.4
KIT, SERV=S-511M0230NE6E5	3911822728	3348123418	3342623004	3342723000	3911401612	108.7
KIT, SERV=S-511M0270NE7E5	3911822729	3348127419	3342627004	3342727000	3911401805	115.0
KIT, SERV=S-511M0330NE7E5	3911822731	3348133419	3342633004	3342733000	3911401562	124.4

SK 511M EE unsealed

Unit identification
on gear housing

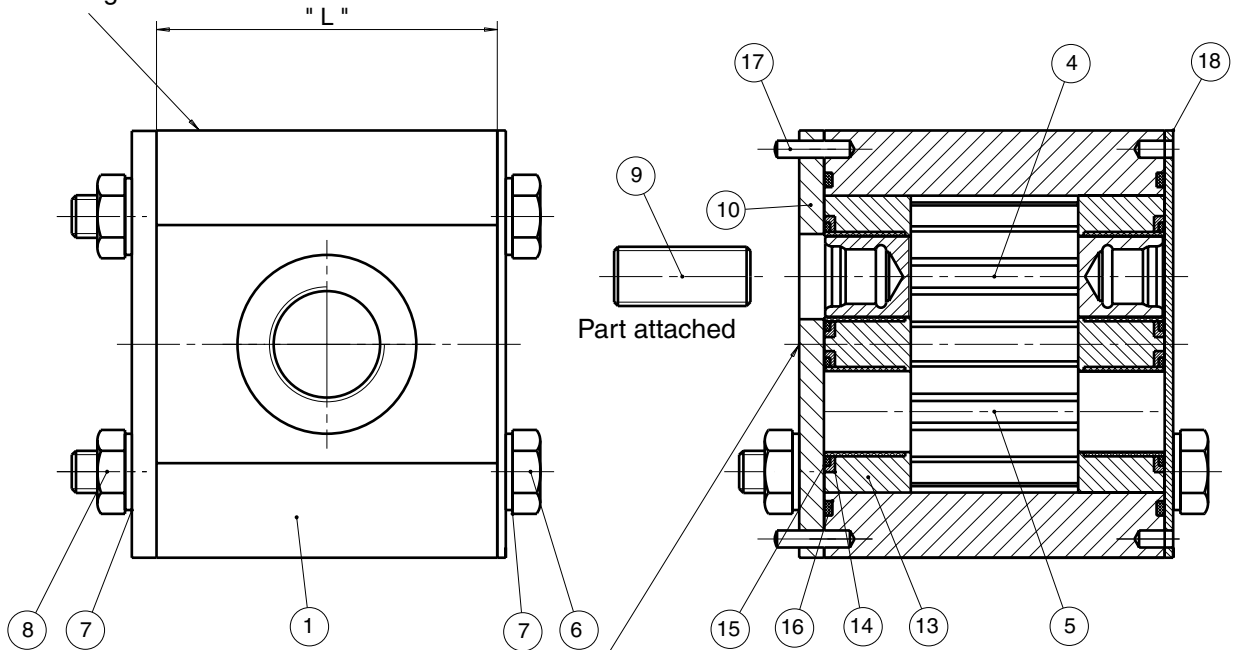

Only for transportation
loosely assembled

Suction hole of mid-plate
located to big port

Unit to be break-in with
special test equipment

Direktion: Clockwise

Pressure: 210 bar

Item	Part No	Required	Description
1	See table	1	Gear housing
4	See table	1	Drive gear
5	See table	1	Driven gear
6	See table	2	Screw
7	3913782231	4	Washer
8	3911451167	2	Nut
9	3321133001	1	Conn. shaft
10	3912183232	1	Mid. plate
13	8898-207-00U	2	Thr. block
14	8611-016-00R	2	Chan. seal
15	8611-015-000	2	BK-up seal
16	9313-145-00B	2	Sect. seal
17	3912080079	2	Dowel pin
18	73910:4046745	1	Cover plate

Code	Kit No.	Gear housing 1x	Drive gear 1x	Driven gear 1x	Screw 2 x over cross	Dim. "L"
KIT, SERV=S-511M0040XE3E2	3911832154	3348104925	3342604010	3342704000	3911401652	47.0
KIT, SERV=S-511M0060XE5E3	3911832155	3348106406	3342606010	3342706000	3911401652	50.1
KIT, SERV=S-511M0080XE5E3	3911832156	3348108406	3342608010	3342708000	3911401652	53.3
KIT, SERV=S-511M0100XE5E3	3911832157	3348110406	3342610010	3342710000	3911401652	56.5
KIT, SERV=S-511M0110XE5E3	3911832158	3348111406	3342611010	3342711000	3911401541	58.0
KIT, SERV=S-511M0140XE6E5	3911832159	3348114418	3342614010	3342714000	3911401542	62.8
KIT, SERV=S-511M0160XE6E5	3911832160	3348116418	3342616010	3342716000	3911401542	65.9
KIT, SERV=S-511M0190XE6E5	3911832161	3348119418	3342619010	3342719000	3911401543	70.6
KIT, SERV=S-511M0230XE6E5	3911832162	3348123418	3342623010	3342723000	3911401544	76.9
KIT, SERV=S-511M0270XE7E5	3911832163	3348127419	3342627010	3342727000	3911401546	83.2
KIT, SERV=S-511M0310XE7E5	3911832164	3348131419	3342631010	3342731000	3911401547	89.5
KIT, SERV=S-511M0330XE7E5	3911832165	3348133419	3342633010	3342733000	3911401548	92.6
KIT, SERV=S-511M0140XE5E3	3911842272	3348114406	3342614010	3342714000	3911401542	62.8
KIT, SERV=S-511M0160XE5E3	3911842273	3348116406	3342616010	3342716000	3911401542	65.9

SK 511M J7J5 unsealed

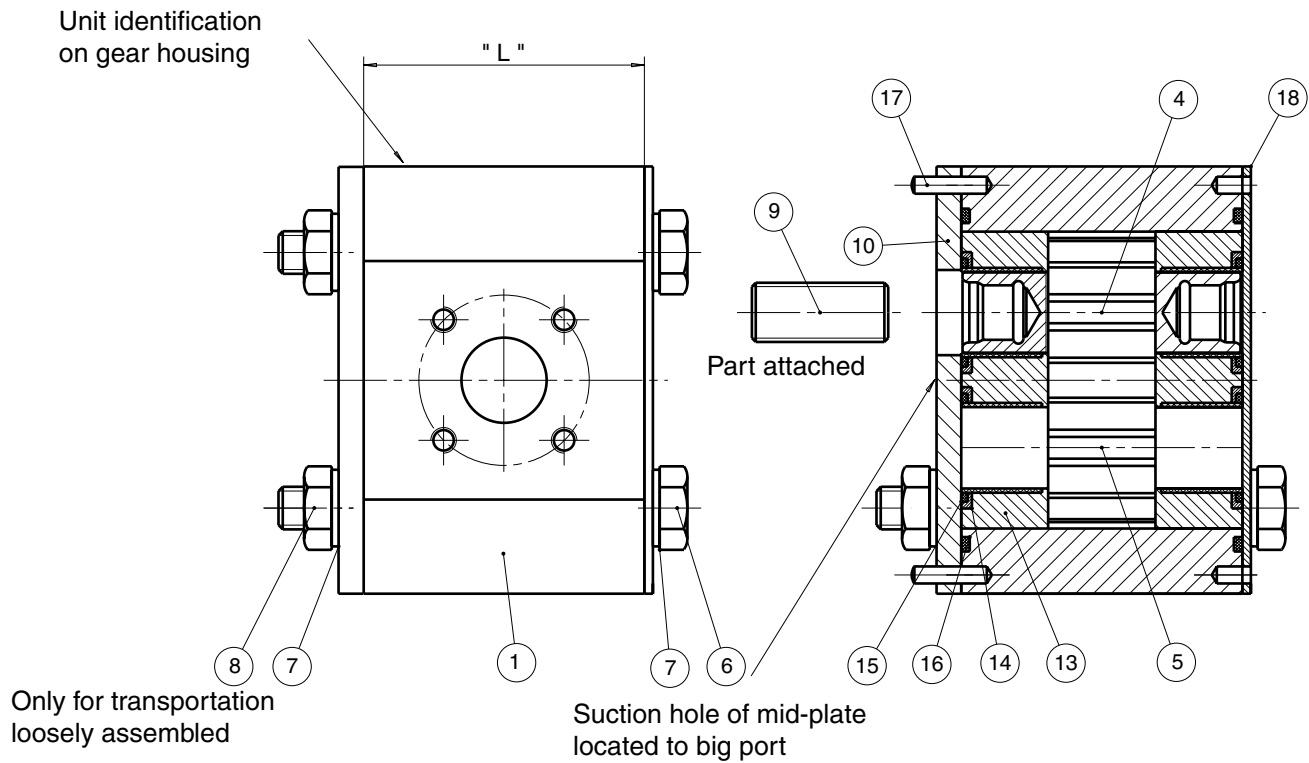

Unit to be break-in with
 special test equipment
 Direktion: Clockwise
 Pressure: 210 bar

Item	Part No	Required	Description
1	See table	1	Gear housing
4	See table	1	Drive gear
5	See table	1	Driven gear
6	See table	2	Screw
7	3913782231	4	Washer
8	3911451167	2	Nut
9	3321133001	1	Conn. shaft
10	3912183232	1	Mid. plate
13	8898-207-00U	2	Thr. block
14	8611-016-00R	2	Chan. seal
15	8611-015-000	2	BK-up seal
16	9313-145-00B	2	Sect. seal
17	3912080079	2	Dowel pin
18	73910:4046745	1	Cover plate

Code	Kit No.	Gear housing 1x	Drive gear 1x	Driven gear 1x	Screw 2 x over cross	Dim. "L"
KIT, SERV=S-511M0040XJ7J5	3911832334	3348104901	3342604010	3342704000	3911401652	47.0
KIT, SERV=S-511M0060XJ7J5	3911832335	3348106901	3342606010	3342706000	3911401652	50.1
KIT, SERV=S-511M0080XJ7J5	3911832336	3348108901	3342608010	3342708000	3911401652	53.3
KIT, SERV=S-511M0100XJ7J5	3911832337	3348110901	3342610010	3342710000	3911401652	56.5
KIT, SERV=S-511M0110XJ7J5	3911832338	3348111901	3342611010	3342711000	3911401541	58.0
KIT, SERV=S-511M0140XJ7J5	3911832339	3348114901	3342614010	3342714000	3911401542	62.8
KIT, SERV=S-511M0160XJ7J5	3911832340	3348116901	3342616010	3342716000	3911401542	65.9
KIT, SERV=S-511M0190XJ7J5	3911832341	3348119901	3342619010	3342719000	3911401543	70.6
KIT, SERV=S-511M0230XJ7J5	3911832342	3348123901	3342623010	3342723000	3911401544	76.9

SK 511M JJ sealed

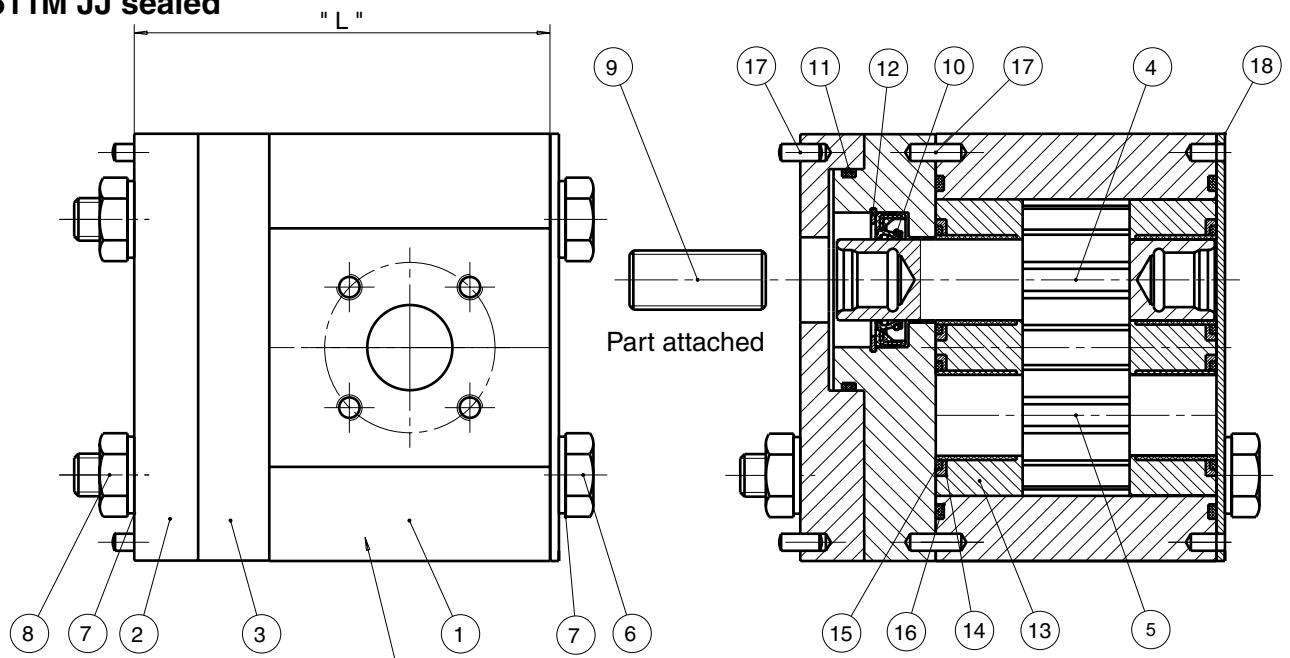

Only for transportation
loosely assembled

Unit identification
on gear housing

Unit to be break-in with
special test equipment

Direktion: Clockwise

Pressure: 210 bar

Item	Part No	Required	Description
1	See table	1	Gear housing
2	3345050204	1	PEC housing.
3	3345051205	1	SEC housing
4	See table	1	Drive gear
5	See table	1	Driven gear
6	See table	2	Screw
7	3913782231	4	Washer
8	3911451167	2	Nut
9	3321133001	1	Conn. shaft
10	9352-061-00T	1	Lip seal
11	3912882187	1	O-ring
12	9211-325-003	1	Snap ring
13	8898-207-00U	2	Thr. block
14	8611-016-00R	2	Chan. seal
15	8611-015-000	2	BK-up seal
16	9313-145-00B	2	Sect. seal
17	3912080078	4	Dowel pin
18	73910:4046745	1	Cover plate

Code	Kit No.	Gear housing 1x	Drive gear 1x	Driven gear 1x	Screw 2 x over cross	Dim. "L"
KIT, SERV=S-511M0040NJ7J5	3911822732	3348104901	3342604004	3342704000	3911401544	78.8
KIT, SERV=S-511M0060NJ7J5	3911822733	3348106901	3342606004	3342706000	3911401544	81.9
KIT, SERV=S-511M0080NJ7J5	3911822734	3348108901	3342608004	3342708000	3911401545	85.1
KIT, SERV=S-511M0100NJ7J5	3911822735	3348110901	3342610004	3342710000	3911401545	88.3
KIT, SERV=S-511M0110NJ7J5	3911822736	3348111901	3342611004	3342711000	3911401546	89.8
KIT, SERV=S-511M0140NJ7J5	3911822737	3348114901	3342614004	3342714000	3911401547	94.6
KIT, SERV=S-511M0160NJ7J5	3911822738	3348116901	3342616004	3342716000	3911401547	97.7
KIT, SERV=S-511M0190NJ7J5	3911832290	3348119901	3342619004	3342719000	3911401548	102.4
KIT, SERV=S-511M0230NJ7J5	3911832291	3348123901	3342623004	3342723000	3911401612	108.7
KIT, SERV=S-511M0190NJ9J8	3911822739	3348119906	3342619004	3342719000	3911401548	102.4
KIT, SERV=S-511M0230NJ9J8	3911822740	3348123906	3342623004	3342723000	3911401612	108.7
KIT, SERV=S-511M0270NJ9J8	3911822741	3348127906	3342627004	3342727000	3911401805	115.0
KIT, SERV=S-511M0330NJ9J8	3911822743	3348133906	3342633004	3342733000	3911401562	124.4

SK 511M LL sealed

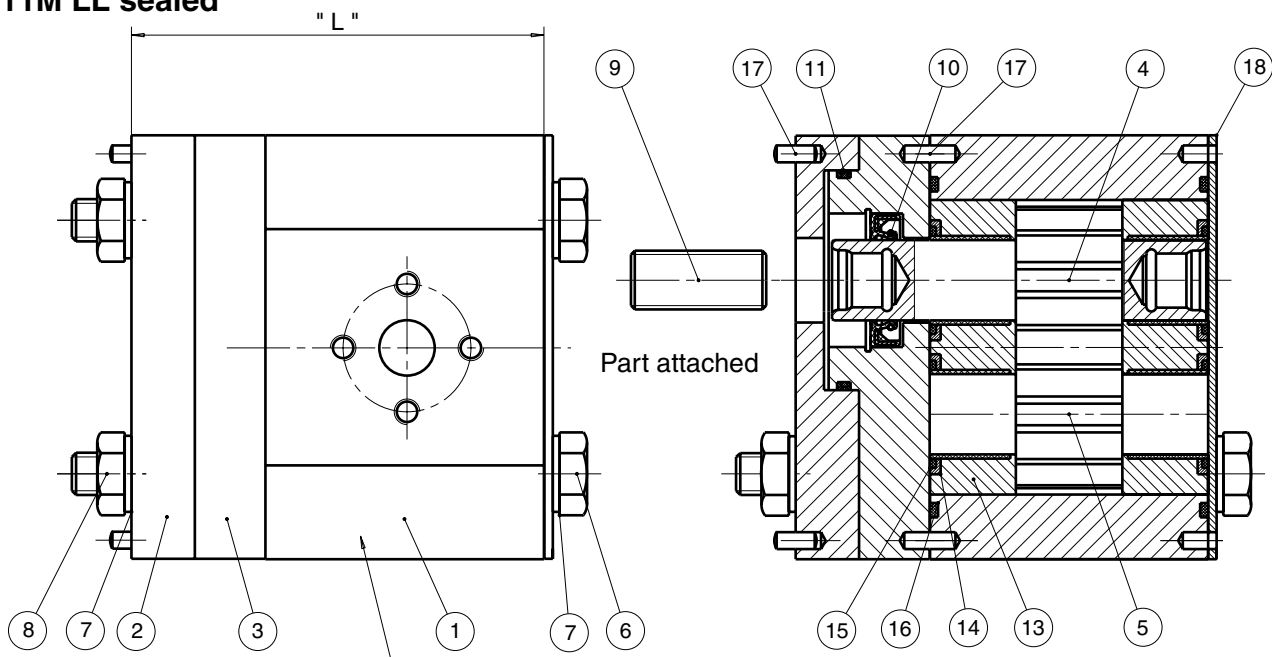

Only for transportation
loosely assembled

Unit identification
on gear housing

Unit to be break-in with
special test equipment

Direktion: Clockwise
Pressure: 210 bar

Item	Part No	Required	Description
1	See table	1	Gear housing
2	3345050204	1	PEC housing.
3	3345051205	1	SEC housing
4	See table	1	Drive gear
5	See table	1	Driven gear
6	See table	2	Screw
7	3911401572	4	Washer
8	3911451167	2	Nut
9	3321133001	1	Conn. shaft
10	9352-061-00T	1	Lip seal
11	3912882187	1	O-ring
12	9211-325-003	1	Snap ring
13	8898-207-00U	2	Thr. block
14	8611-016-00R	2	Chan. seal
15	8611-015-000	2	BK-up seal
16	9313-145-00B	2	Sect. seal
17	3912080078	4	Dowel pin
18	73910:4046745	1	Cover plate

Code	Kit No.	Gear housing 1x	Drive gear 1x	Driven gear 1x	Screw 2 x over cross	Dim. "L"
KIT, SERV=S-511M0040NL1L1	3911822617	3348104908	3342604004	3342704000	3911401544	78.8
KIT, SERV=S-511M0060NL1L1	3911822618	3348106908	3342606004	3342706000	3911401544	81.9
KIT, SERV=S-511M0080NL1L1	3911822619	3348108908	3342608004	3342708000	3911401545	85.1
KIT, SERV=S-511M0100NL2L1	3911822620	3348110907	3342610004	3342710000	3911401545	88.3
KIT, SERV=S-511M0110NL2L1	3911822621	3348111907	3342611004	3342711000	3911401546	89.8
KIT, SERV=S-511M0140NL2L1	3911822622	3348114907	3342614004	3342714000	3911401547	94.6
KIT, SERV=S-511M0160NL2L1	3911822623	3348116907	3342616004	3342716000	3911401547	97.7
KIT, SERV=S-511M0190NL2L2	3911822624	3348119973	3342619004	3342719000	3911401548	102.4
KIT, SERV=S-511M0230NL2L2	3911822625	3348123973	3342623004	3342723000	3911401612	108.7
KIT, SERV=S-511M0270NL2L2	3911822626	3348127973	3342627004	3342727000	3911401805	115.0
KIT, SERV=S-511M0330NL2L2	3911822628	3348133973	3342633004	3342733000	3911401562	124.4

SK 511M LL unsealed

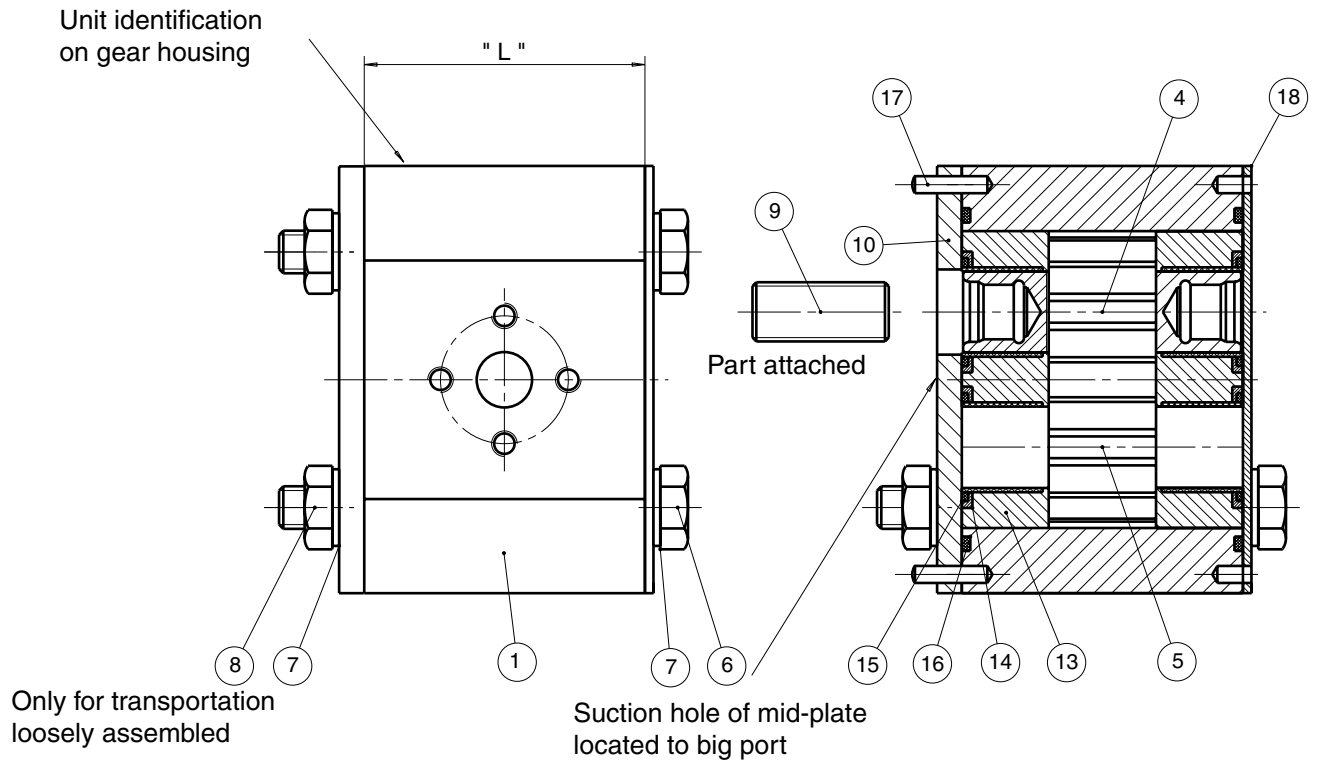

Item	Part No	Required	Description
1	See table	1	Gear housing
4	See table	1	Drive gear
5	See table	1	Driven gear
6	See table	2	Screw
7	3913782231	4	Washer
8	3911451167	2	Nut
9	3321133001	1	Conn. shaft
10	3912183232	1	Mid. plate
13	8898-207-00U	2	Thr. block
14	8611-016-00R	2	Chan. seal
15	8611-015-000	2	BK-up seal
16	9313-145-00B	2	Sect. seal
17	3912080079	2	Dowel pin
18	73910:4046745	1	Cover plate

Unit to be break-in with special test equipment
 Direktion: Clockwise
 Pressure: 210 bar

Code	Kit No.	Gear housing 1x	Drive gear 1x	Driven gear 1x	Screw 2 x over cross	Dim. "L"
KIT, SERV=S-511M0040XL1L1	3911832577	3348104908	3342604010	3342704000	3911401652	47.0
KIT, SERV=S-511M0060XL1L1	3911832578	3348106908	3342606010	3342706000	3911401652	50.1
KIT, SERV=S-511M0080XL1L1	3911832579	3348108908	3342608010	3342708000	3911401652	53.3
KIT, SERV=S-511M0100XL2L1	3911832580	3348110908	3342610010	3342710000	3911401652	56.5
KIT, SERV=S-511M0110XL2L1	3911832581	3348111908	3342611010	3342711000	3911401541	58.0
KIT, SERV=S-511M0140XL2L1	3911832582	3348114908	3342614010	3342714000	3911401542	62.8
KIT, SERV=S-511M0160XL2L1	3911832583	3348116908	3342616010	3342716000	3911401542	65.9
KIT, SERV=S-511M0190XL2L2	3911832584	3348119973	3342619010	3342719000	3911401543	70.6
KIT, SERV=S-511M0230XL2L2	3911832585	3348123973	3342623010	3342723000	3911401544	76.9

SK 517 M EE sealed

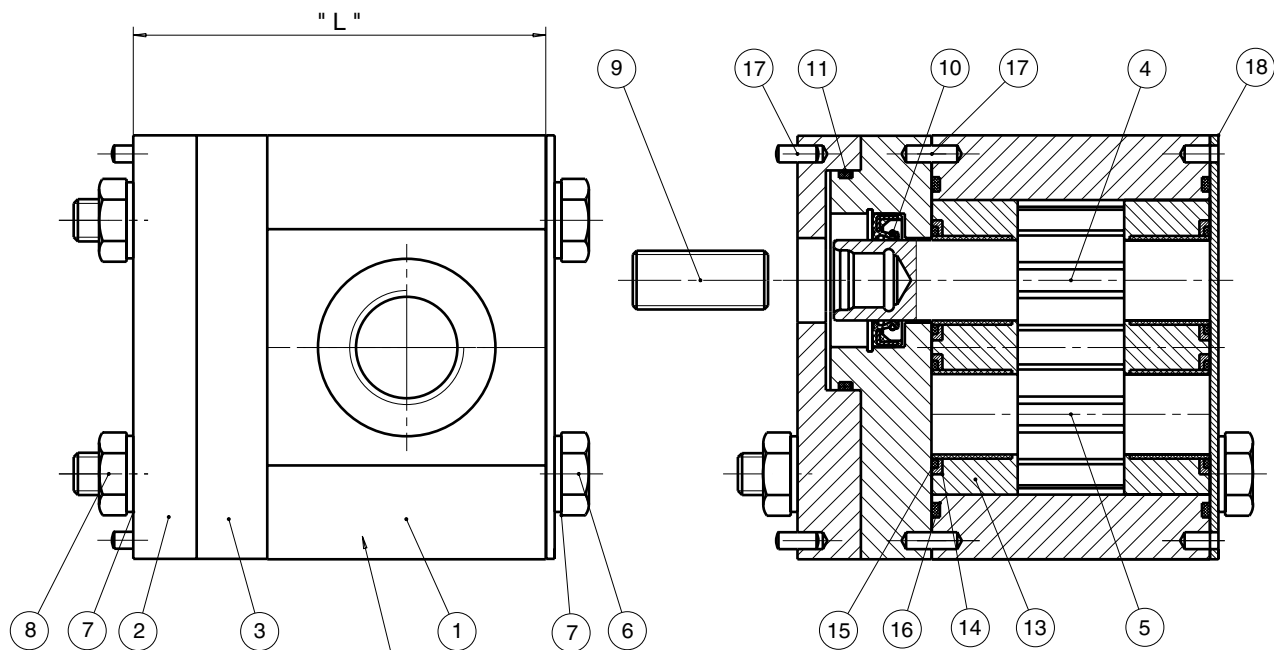

Only for transportation
loosely assembled

Unit identification
on gear housing

Item	Part No	Required	Description
1	See table	1	Gear housing
2	3335050205	1	PEC housing.
3	3335051205	1	SEC housing
4	See table	1	Drive gear
5	See table	1	Driven gear
6	See table	2	Screw
7	3913782232	4	Washer
8	3911451149	2	Nut
9	3241133001	1	Conn. shaft
10	3912883058	1	Lip seal
11	3912882187	1	O-ring
13	3912185093	2	Thr. block
14	3912882161	2	Chan. seal
15	3912882162	2	BK-up seal
16	3912882148	2	Sect. seal
17	3912080080	4	Dowel pin
18	73910:4047012	1	Cover plate

Unit to be break-in with
special test equipment

Direktion: Clockwise

Code	Kit No.	Gear housing 1x	Drive gear 1x	Driven gear 1x	Screw 2 x over cross	Dim. "L"	Max pressure bar
KIT, SERV=S-517A0160NE6E5	3911822756	3338116418	3332616001	3332716000	3911401556	113.1	250
KIT, SERV=S-517A0230NE7E6	3918122758	3338123428	3332623001	3332723000	3911401577	120.2	250
KIT, SERV=S-517A0280NE7E6	3911822760	3338128428	3332628001	3332728000	3911401581	125.2	250
KIT, SERV=S-517A0330NE7E6	3911822761	3338133428	3332633001	3332733000	3911401581	130.3	250
KIT, SERV=S-517A0440NE8E6	3911822763	3338144429	3332644001	3332744000	3911401582	141.4	220

SK 517 M EE unsealed

Unit identification
on gear housing

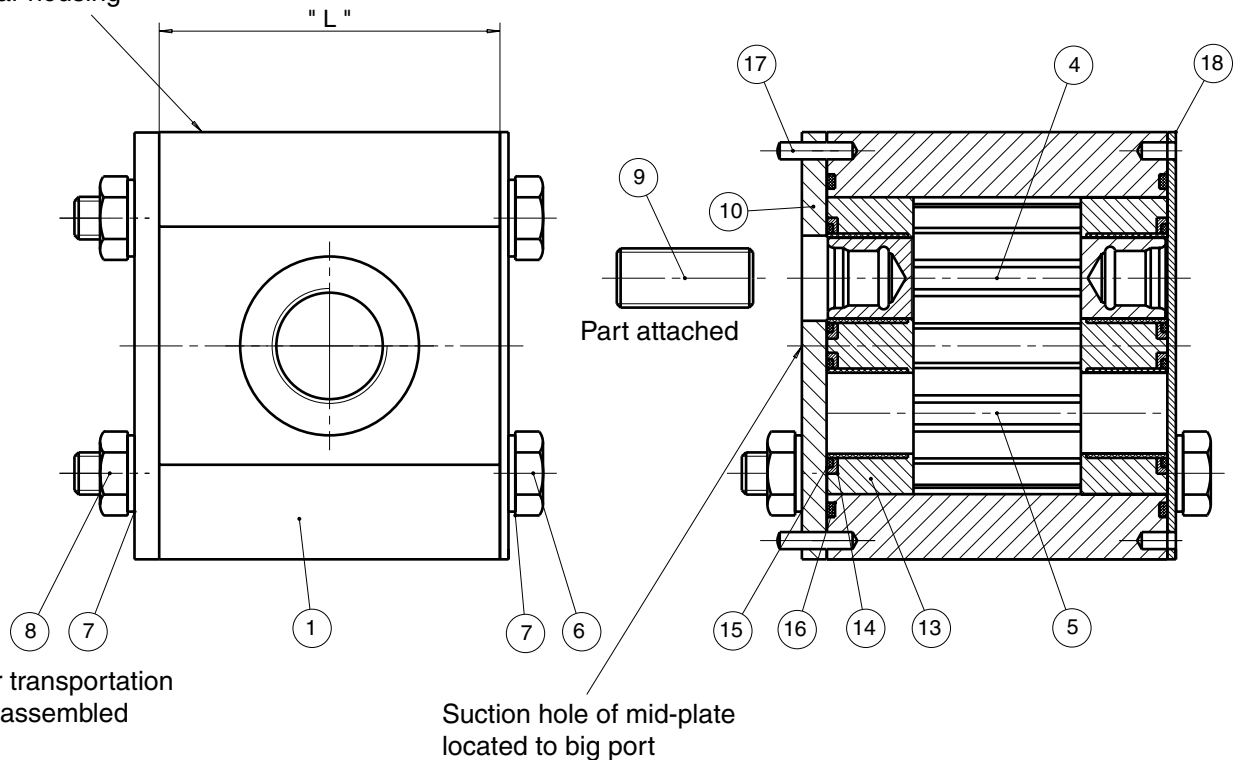

Only for transportation
loosely assembled

Suction hole of mid-plate
located to big port

Unit to be break-in with
special test equipment

Direktion: Clockwise

Item	Part No	Required	Description
1	See table	1	Gear housing
4	See table	1	Drive gear
5	See table	1	Driven gear
6	See table	2	Screw
7	3913782232	4	Washer
8	3911451149	2	Nut
9	3241133001	1	Conn. shaft
10	3912183238	1	Mid. plate
13	3912185093	2	Thr. block
14	3912882161	2	Chan. seal
15	3912882162	2	BK-up seal
16	3912882148	2	Sect. seal
17	3912080081	2	Dowel pin
18	73910:4047012	1	Cover plate

Code	Kit No.	Gear housing 1x	Drive gear 1x	Driven gear 1x	Screw 2 x over cross	Dim. "L"	Max pressure bar
KIT, SERV=S-517M0140XE6E5	3911832187	3338114418	3332614010	3332714000	3911401549	68.3	
KIT, SERV=S-517M0160XE6E5	3911832188	3338116418	3332616010	3332716000	3911401549	70.3	250
KIT, SERV=S-517M0190XE6E5	3911832189	3338119418	3332619010	3332719000	3911401549	73.3	250
KIT, SERV=S-517M0230XE7E6	3911832190	3338123428	3332623010	3332723000	3911401549	77.4	250
KIT, SERV=S-517M0250XE7E6	3911832191	3338125428	3332625010	3332725000	3911401549	79.4	250
KIT, SERV=S-517M0280XE7E6	3911832192	3338128428	3332628010	3332728000	3911401549	82.4	250
KIT, SERV=S-517M0330XE7E6	3911832193	3338133428	3332633010	3332733000	3911401549	87.5	250
KIT, SERV=S-517M0380XE7E6	3911832194	3338138428	3332638010	3332738000	3911401555	92.5	250
KIT, SERV=S-517M0440XE8E6	3911832195	3338144429	3332644010	3332744000	3911401555	98.6	220
KIT, SERV=S-517M0520XE8E6	3911832196	3338152429	3332652010	3332752000	3911401556	106.7	200
KIT, SERV=S-517M0700XE8E6	3911832198	3338170429	3332670010	3332770000	3911401581	124.9	160

SK 517 M J9J8 unsealed

Unit identification
on gear housing

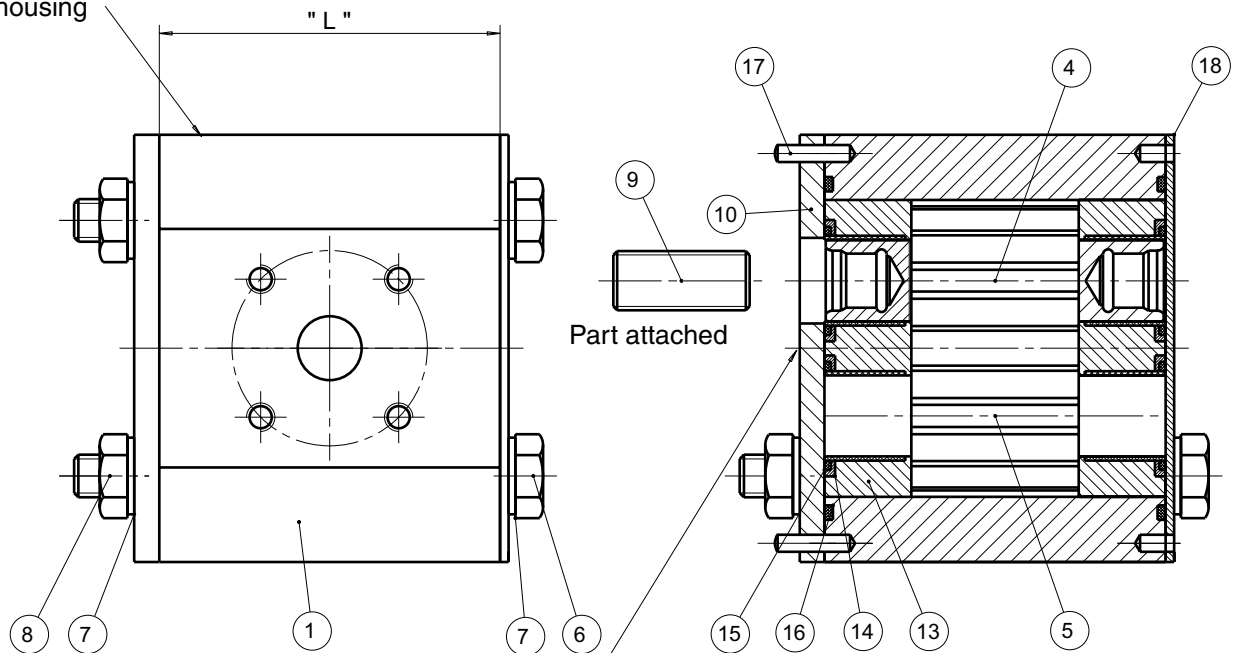

Only for transportation
loosely assembled

Suction hole of mid-plate
located to big port

Item	Part No	Required	Description
1	See table	1	Gear housing
4	See table	1	Drive gear
5	See table	1	Driven gear
6	See table	2	Screw
7	3913782232	4	Washer
8	3911451149	2	Nut
9	3241133001	1	Conn. shaft
10	3912183238	1	Mid. plate
13	3912185093	2	Thr. block
14	3912882161	2	Chan. seal
15	3912882162	2	BK-up seal
16	3912882148	2	Sect. seal
17	3912080081	2	Dowel pin
18	73910:4047012	1	Cover plate

Unit to be break-in with
special test equipment

Direktion: Clockwise

Code	Kit No.	Gear housing 1x	Drive gear 1x	Driven gear 1x	Screw 2 x over cross	Dim. "L"	Max pressure bar
KIT, SERV=S-517M0190XJ9J8	3911842281	3338119906	3332619010	3332719000	3911401549	73.3	250
KIT, SERV=S-517M0230XJ9J8	3911842282	3338123906	3332623010	3332723000	3911401549	77.4	250
KIT, SERV=S-517M0280XJ9J8	3911842283	3338128906	3332628010	3332728000	3911401549	82.4	250
KIT, SERV=S-517M0330XJ9J8	3911842284	3338133906	3332633010	3332733000	3911401549	87.5	250
KIT, SERV=S-517M0380XJ9J8	3911842285	3338138906	3332638010	3332738000	3911401555	92.5	250

SK 517 M LL unsealed

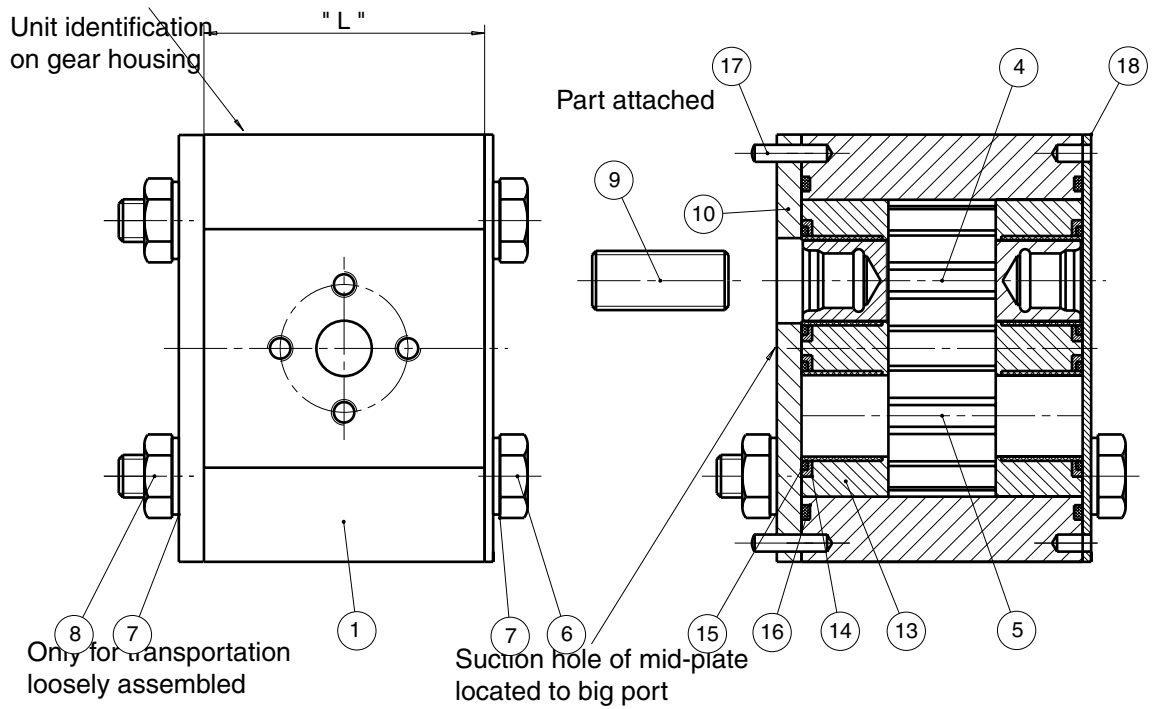

Unit to be break-in with special test equipment

Direktion: Clockwise

Item	Part No	Required	Description
1	See table	1	Gear housing
4	See table	1	Drive gear
5	See table	1	Driven gear
6	See table	2	Screw
7	3913782232	4	Washer
8	3911451149	2	Nut
9	3241133001	1	Conn. shaft
10	3912183238	1	Mid. plate
13	3912185093	2	Thr. block
14	3912882161	2	Chan. seal
15	3912882162	2	BK-up seal
16	3912882148	2	Sect. seal
17	3912080081	2	Dowel pin
18	73910:4047012	1	Cover plate

Code	Kit No.	Gear housing 1x	Drive gear 1x	Driven gear 1x	Screw 2 x over cross	Dim. "L"	Max pressure bar
KIT, SERV=S-517M0160XL3L2	3911832891	3338116911	3332616010	3332716000	3911401549	70.3	250
KIT, SERV=S-517M0230XL3L2	3911832892	3338123911	3332623010	3332723000	3911401549	77.4	250
KIT, SERV=S-517M0280XL3L2	3911832893	3338128911	3332628010	3332728000	3911401549	82.4	250
KIT, SERV=S-517M0330XL3L2	3911832894	3338133911	3332633010	3332733000	3911401549	87.5	250
KIT, SERV=S-517M0380XL3L2	3911832895	3338138911	3332638010	3332738000	3911401555	92.5	250
KIT, SERV=S-517M0440XL3L2	3911832896	3338144911	3332644010	3332744000	3911401555	98.6	220

SK 517 M DD unsealed

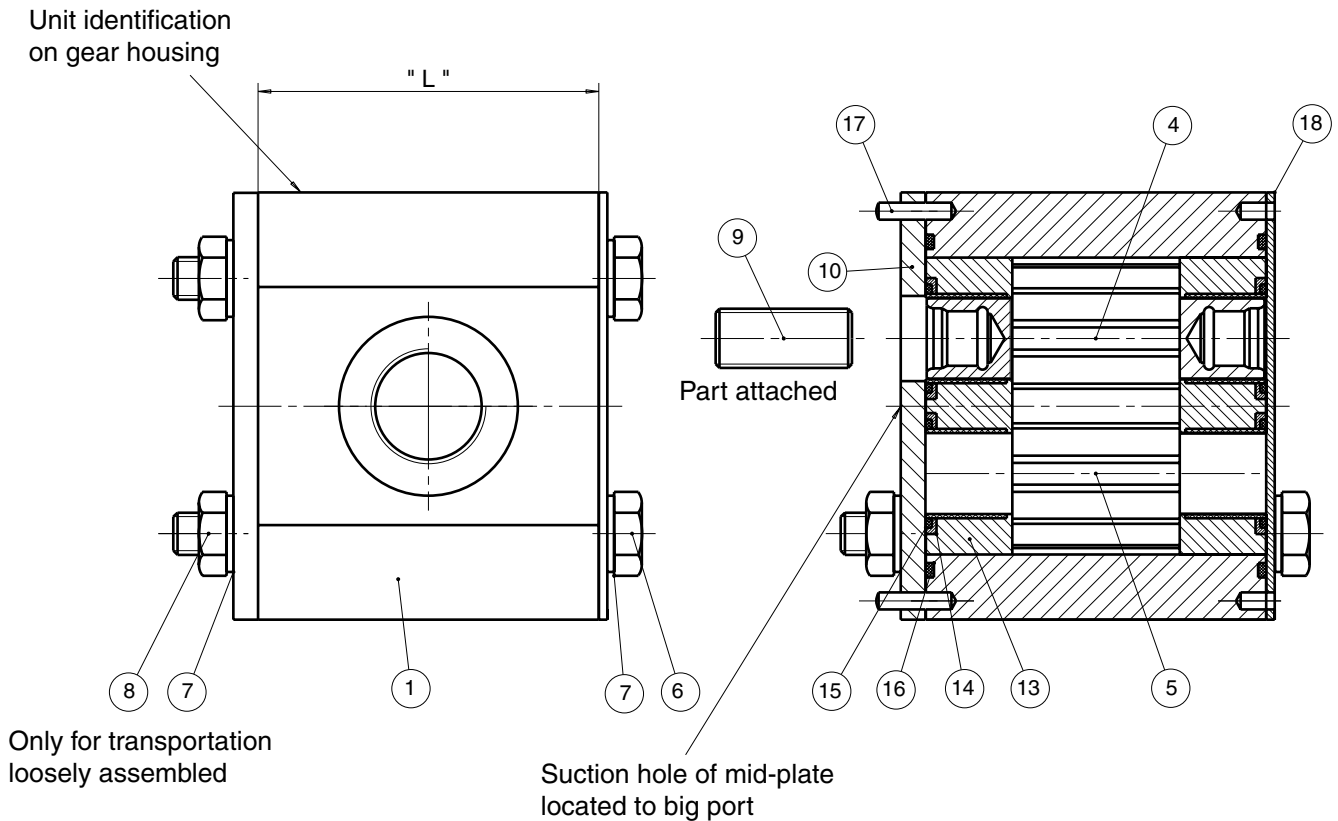

Item	Part No	Required	Description
1	See table	1	Gear housing
4	See table	1	Drive gear
5	See table	1	Driven gear
6	See table	2	Screw
7	3913782232	4	Washer
8	3911451149	2	Nut
9	3241133001	1	Conn. shaft
10	3912183238	1	Mid. plate
13	3912185093	2	Thr. block
14	3912882161	2	Chan. seal
15	3912882162	2	BK-up seal
16	3912882148	2	Sect. seal
17	3912080081	2	Dowel pin
18	73910:4047012	1	Cover plate

Unit to be break-in to max pressure with special test equipment

Direktion: Clockwise

Code	Kit No.	Gear housing 1x	Drive gear 1x	Driven gear 1x	Screw 2 x over cross	Dim. "L"	Max pressure bar
KIT,SERV=S-517M0230XD6D5	3911842601	333 8123 318	3332623010	3332723000	3911401549	77.4	250
KIT,SERV=S-517M0280XD7D5	3911842602	333 8128 319	3332628010	3332728000	3911401549	82.4	250
KIT,SERV=S-517M0330XD7D5	3911842603	3338138328	3332633010	3332733000	3911401549	87.5	250
KIT,SERV=S-517M0380XD7D6	3911842604	3338133319	3332638010	3332738000	3911401555	92.5	250
KIT,SERV=S-517M0440XD7D6	3911842605	3338144328	3332644010	3332744000	3911401555	98.6	220

Tandem pump unsealed between sections

Series PGP, PGM 500

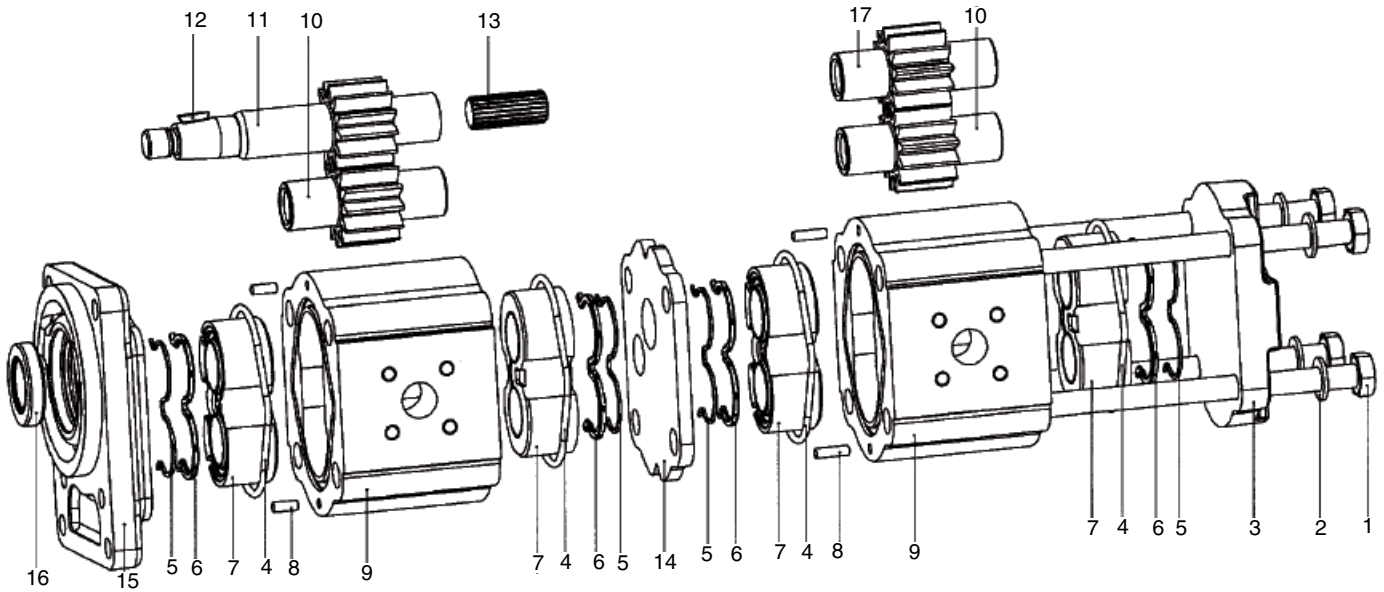

No.:	Description
1	Screw / Bolt
2	Spring washer
3	End cover
4	Body O - ring
5	Back up seal
6	Seal element
7	Thrust block
8	Pin
9	Body

No.:	Description
10	Driven Gear
11	Drive shaft
12	Woodruff key
13	Connecting shaft
14	Mid plate
15	Mounting flange
16	Shaft seal
17	Drive gear rear section

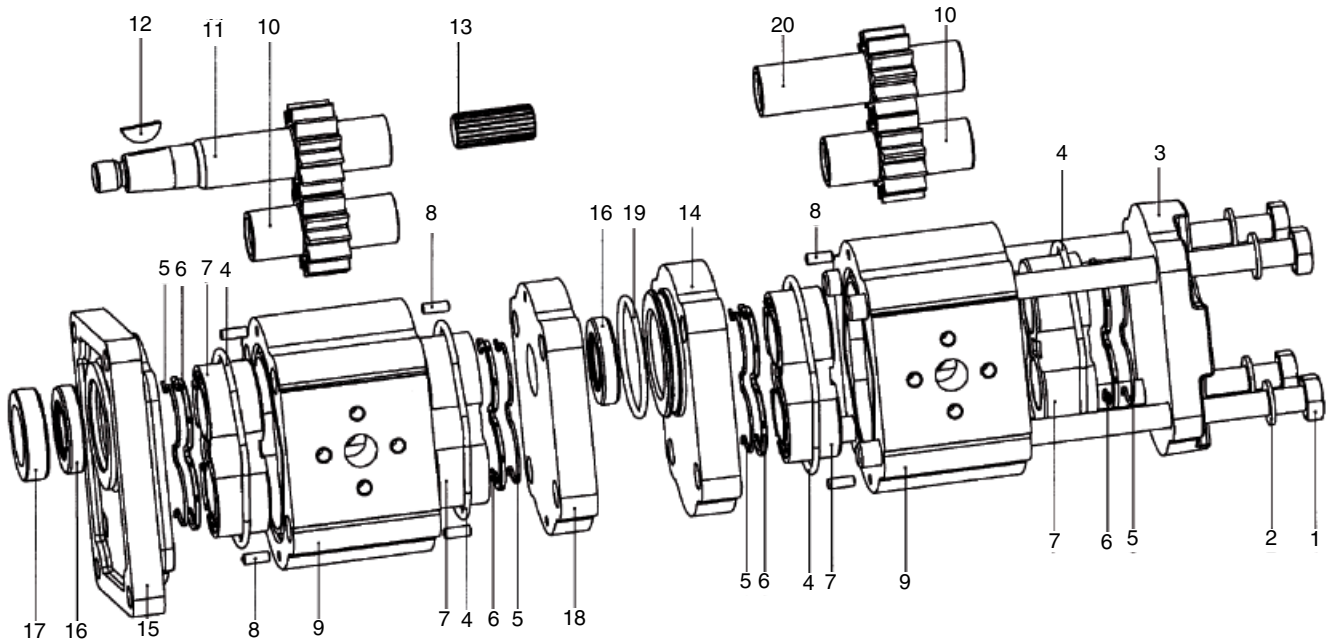

No.:	Description
1	Screw / Bolt
2	Spring washer
3	End cover
4	Body O - ring
5	Back up seal
6	Seal element
7	Thrust block
8	Pin
9	Body
10	Driven Gear

No.:	Description
11	Drive shaft
12	Woodruff key
13	Connecting shaft
14	Mid plate 3345051205
15	Mounting flange
16	Shaft seal
17	Snap ring
18	Mid plate 3345050208
19	O-ring
20	Drive gear rear section

S8F4, Sub-assembly (511)
Part No 3911822365

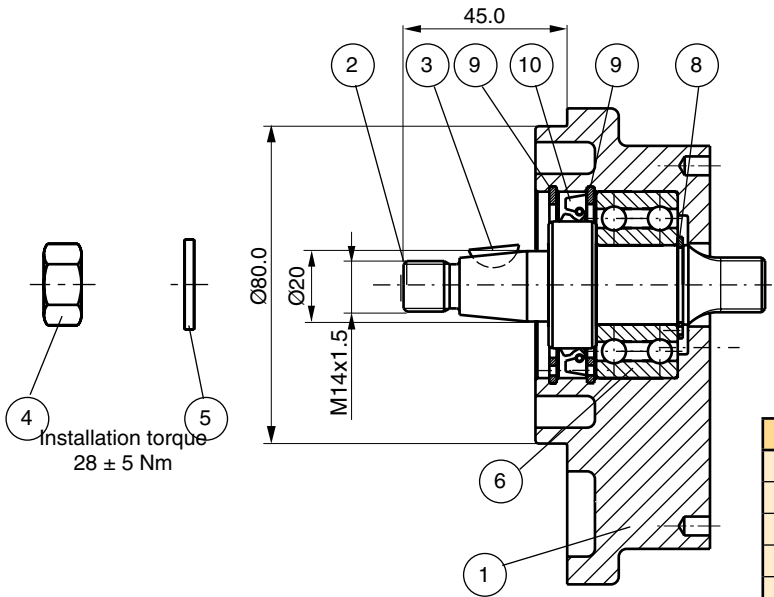

4 Installation torque
 $28 \pm 5 \text{ Nm}$

Item	Part No	Required	Description
1	3345041215	1	Housing section
2	3321500605	1	Shaft, cont.
3	3911781079	1	Key
4	3911451161	1	Nut
5	3913782260	1	Washer
6	3910381126	1	Ball bearing
8	3912681550	1	Snap ring
9	3912681549	2	Snap ring
10	3912883197	1	Lip seal BABSL 32x47x6

D1L7, Sub-assembly (511)
Part No 3911822471

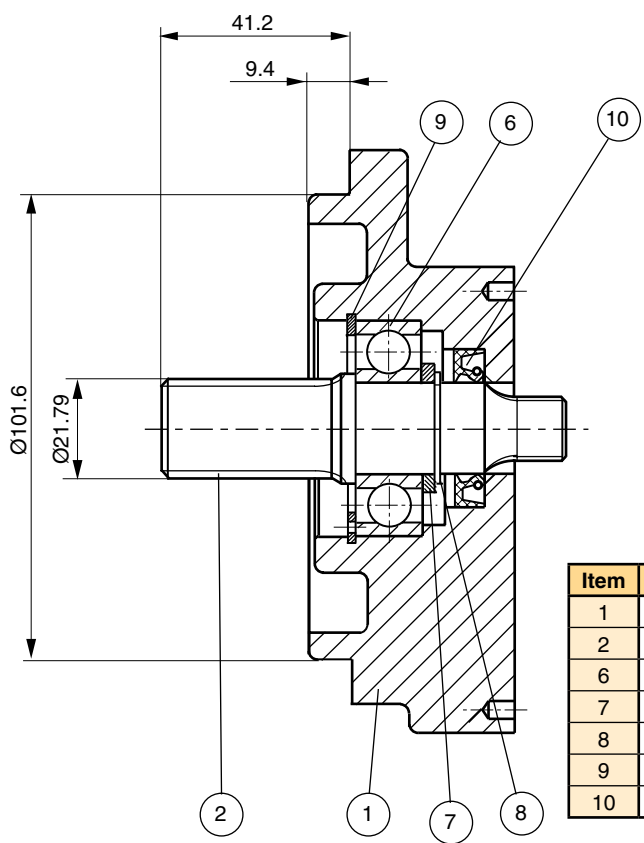

Item	Part No	Required	Description
1	3345021218	1	Housing section
2	3321000404	1	Shaft, cont.
6	3910381116	1	Ball bearing
7	3913384433	1	Spacer
8	3912681550	1	Snap ring
9	3912681549	1	Snap ring
10	3912883181	1	Lip seal BABSL 32x47x6

K7L2, Sub-assembly (511)
Part No 3911822586

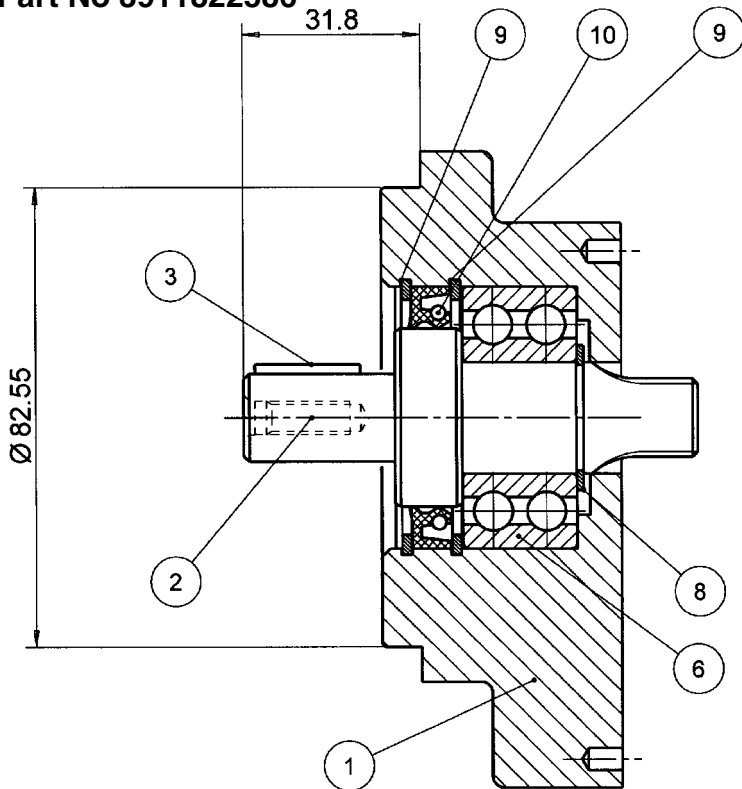

Item	Part No	Required	Description
1	3345021216	1	Housing section
2	3341500203	1	Shaft, cont.
3	3911781091	1	Key
6	3910381126	1	Ball bearing
8	3912681550	1	Snap ring
9	3912681549	2	Snap ring
10	3912883197	1	Lip seal BABSL 32x47x6

M2L3, Sub-assembly (517)
Part No 3911842243

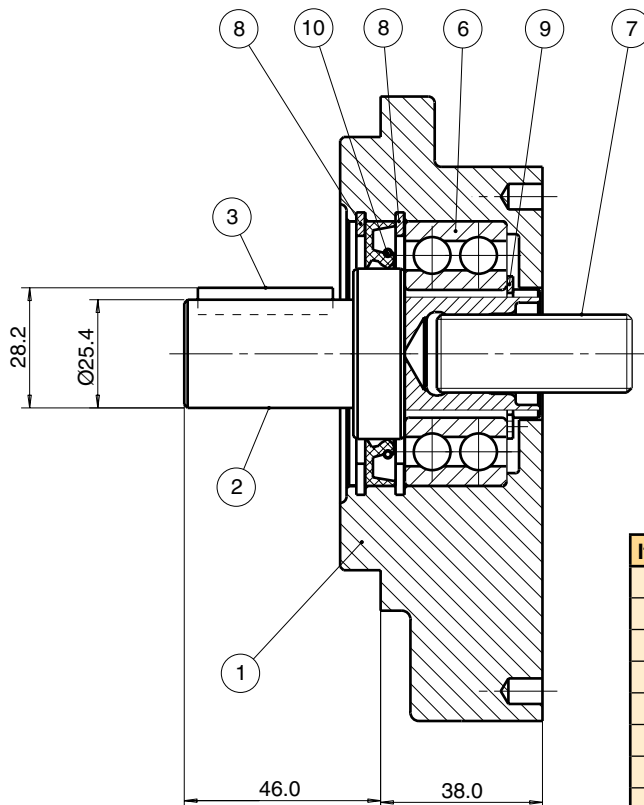

Item	Part No	Required	Description
1	3335021213	1	Housing section
2	73330:4116395	1	Shaft, cont.
3	3911781082	1	Key
6	3910381127	1	Ball bearing
7	3241133001	1	SFT. Connection
8	3912686064	2	Snap ring
9	3912685013	1	Snap ring
10	8697527	1	Lip seal

PGP511B...CS1D4NJ7J5S-502A...XJ4J3B1B1
exploded view

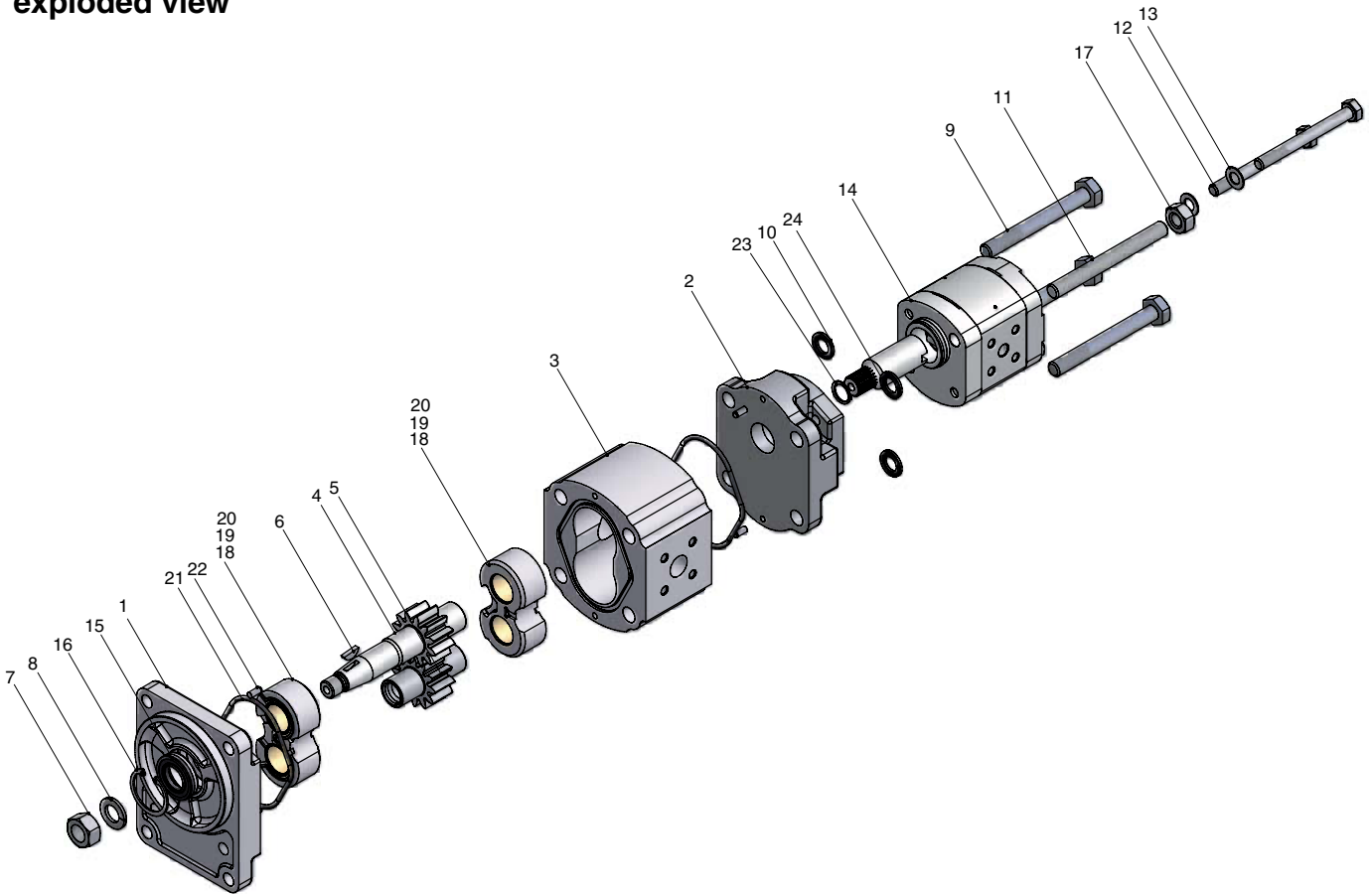

Item	Part No	Required	Description
1	3345041203	1	Housing sec
2	3343040100	1	Housing pec
3	33481xx901	1	Housing gear
4	33419xx600	1	Drive gear
5	33427xx000	1	Driven gear
6	3911781099	1	Key
7	3911451160	1	Nut
8	3913782259	1	Washer
9	3911401856	3	Screw (88 mm)
10	3913782231	4	Washer
11	3911425628	1	Stud (98 mm)
12	3911401552	2	Screw (80 mm)
13	3913782256	2	Washer
14		1	PGP502A...CV2P3XJ4J3B1B1
15	8301-019-00K	1	Lip seal
16	9211-323-00B	1	Snap ring
17	3911451167	1	Nut
18	8898-207-00U	2	THRBLK/BSHG
19	8611-016-00R	2	Chan. seal
20	8611-015-000	2	BK-UP seal
21	9313-145-00B	2	Sect. seal
22	3912080078	4	Dowel pin
23	3912681568	1	Snap ring
24	3321133002	1	Connecting Shaft

PGP517B....CT1D7NJ9J8S-511A....NJ7J5B1B1
exploded view

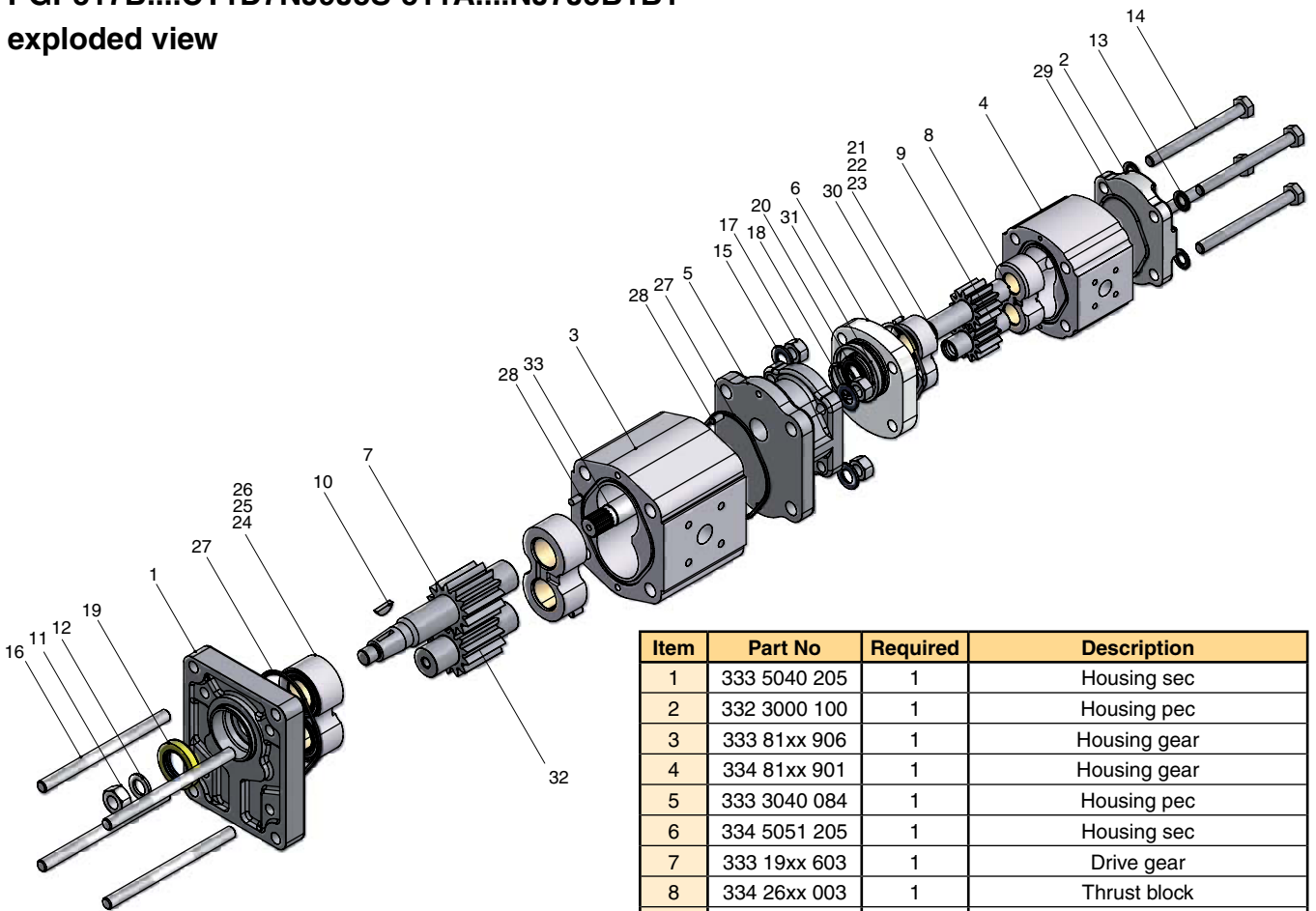

Item	Part No	Required	Description
1	333 5040 205	1	Housing sec
2	332 3000 100	1	Housing pec
3	333 81xx 906	1	Housing gear
4	334 81xx 901	1	Housing gear
5	333 3040 084	1	Housing pec
6	334 5051 205	1	Housing sec
7	333 19xx 603	1	Drive gear
8	334 26xx 003	1	Thrust block
9	334 27xx 000	1	Driven gear
10	391 1781 115	1	Key
11	391 1451 161	1	Nut
12	391 3782 260	1	Washer
13	391 3782 231	4	Washer
14		4	Cap screw
15	391 3782 232	4	Washer
16		4	Stud DIN 939
17	391 1451 149	4	Nut
18	9211-325-003	1	Snap ring
19	391 2883 058	1	Lip seal
20	9352-061-00T	1	Lip seal
21	8898-207-00U	2	THRBLK/BSHG
22	8611-016-00R	2	Chan. seal
23	8611-015-000	2	BK-UP seal
24	391 2185 093	2	THRBLK/BSHG
25	391 2882 161	2	Chan. seal
26	391 2882 162	2	BK-UP seal
27	391 2882 148	2	Sect. seal
28	391 2080 080	4	Dowel pin
29	9313-145-00B	2	Sect. seal
30	391 2080 078	2	Dowel pin
31	391 2882 187	1	O-ring
32	333 27xx 000	1	Driven gear
33	333 1133 004	1	Connecting Shaft

Outboard Bearing

Units subject to axial or radial loads, for instance drive with V-belts or gear wheels, must be specified with an outboard bearing.

The diagrams below show the maximum axial or radial loads that can be tolerated referred to a bearing life of $L_H = 1000$ h.

F_r is reduced by 0,7 F_a when axial loading is applied.

Outboard Bearing Code L2, L3, F4

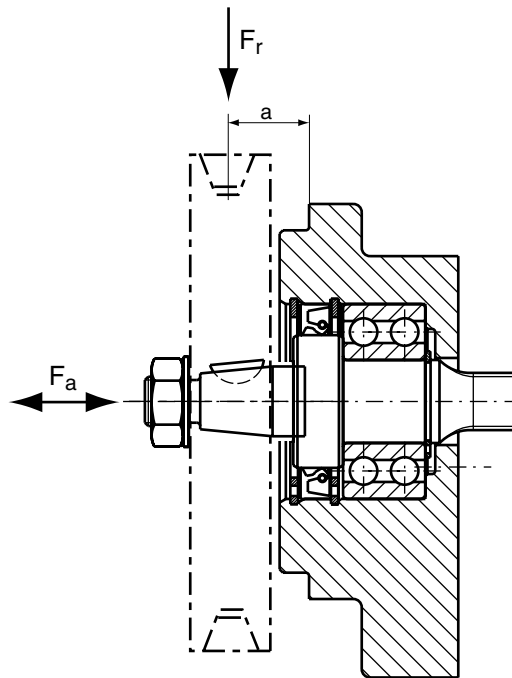

Shaft load for outboard bearings PGP/PGM 511

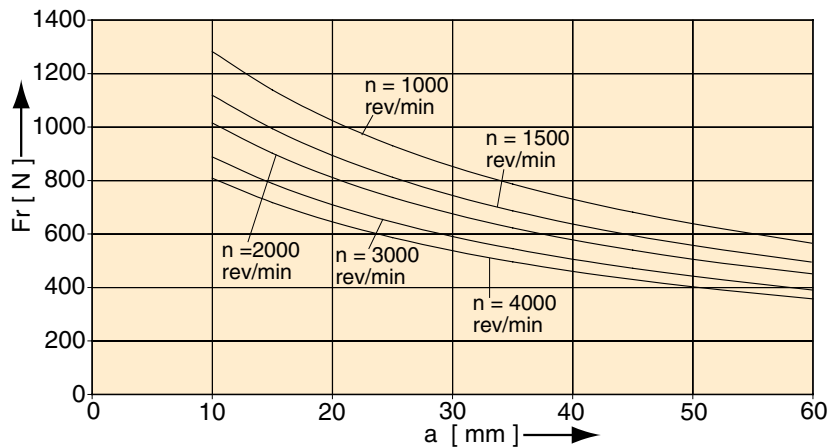

PGP502AxxxxCV2P3XE2E2B1B1

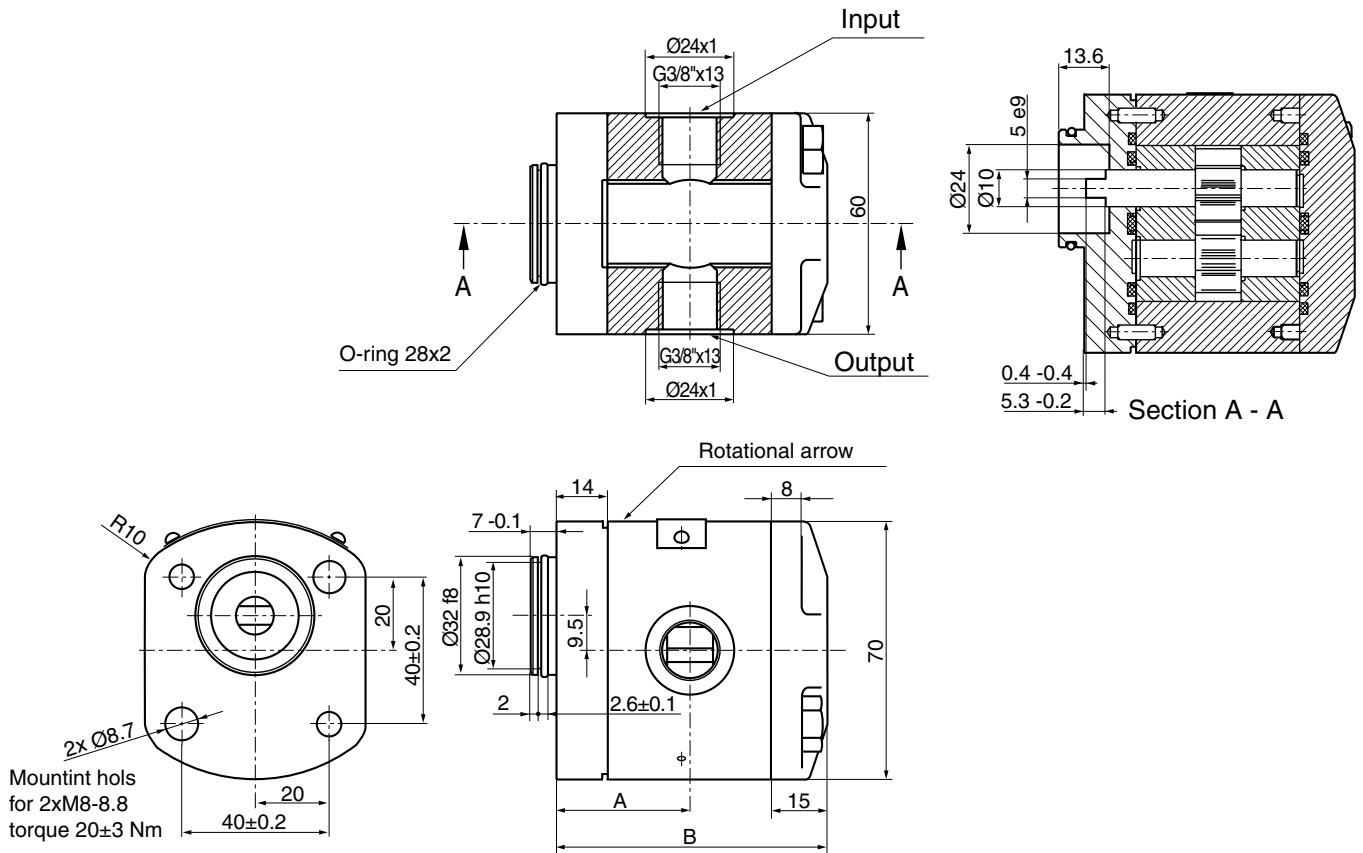

Displacement xxx	cm ³ /rev	Dimension		Speed of rotation		Max pressure bar	Weight kg	Rotation Clockwise
		A	B	min. rpm	max. rpm			
0008	0.8	32.6	64.3	500	5000	280	1.05	3309111391
0012	1.2	33.4	65.8	500	5000	280	1.05	3309111392
0016	1.6	34.1	67.3	500	5000	280	1.05	3309111393
0021	2.1	34.9	68.9	500	4500	280	1.05	3309111394
0025	2.5	35.7	70.5	500	4500	280	1.15	
0033	3.3	37.2	73.5	500	3500	280	1.15	
0036	3.6	37.8	74.6	500	3200	260	1.15	
0043	4.3	39.2	77.5	500	2600	250	1.25	
0048	4.8	40.0	79.0	500	2400	230	1.35	
0058	5.8	41.9	82.8	500	2000	200	1.35	
0062	6.2	42.6	84.3	500	1800	180	1.45	
0079	7.9	45.8	90.6	500	1500	160	1.55	

PGP502AxxxxCV2P3XE3E2B1B1

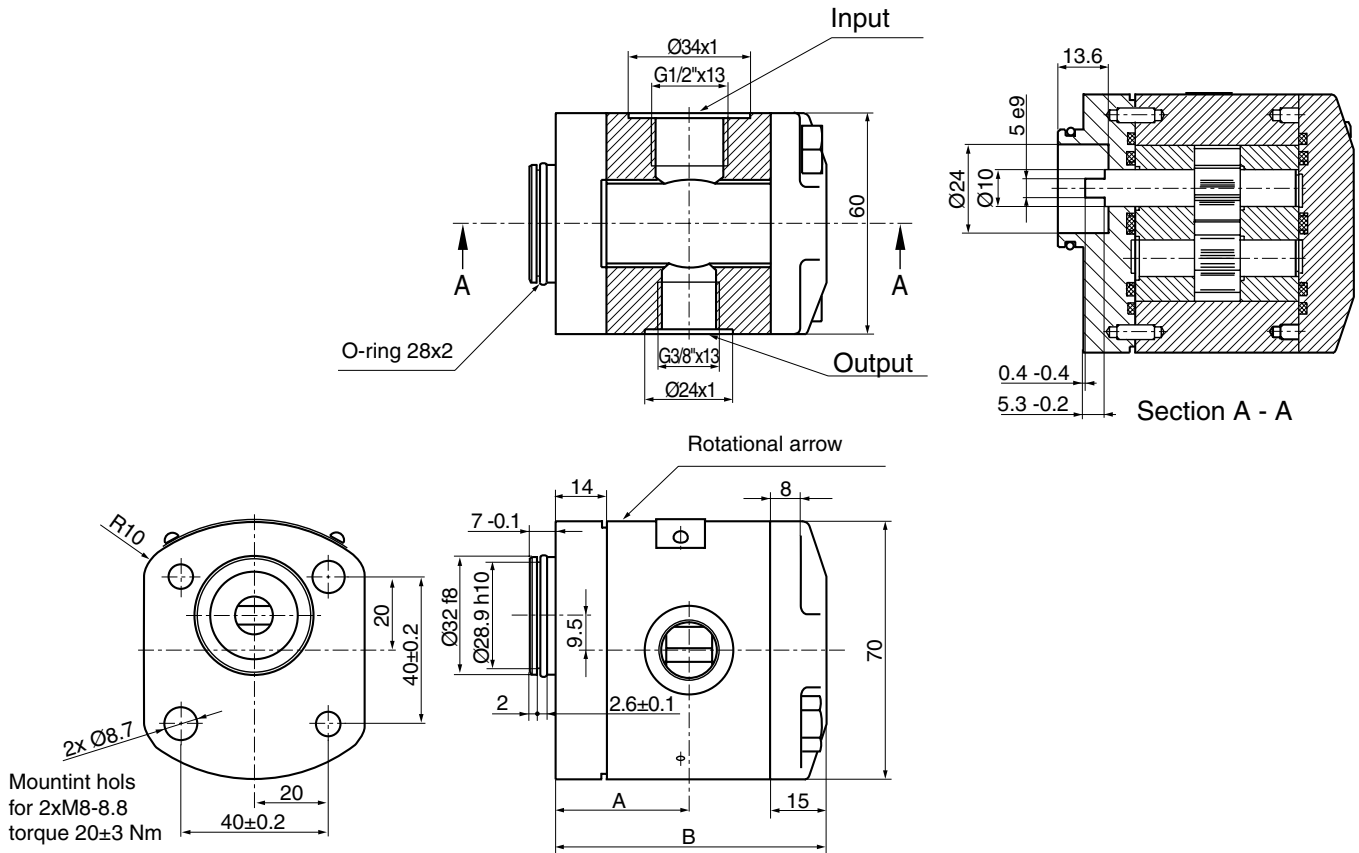

Displacement xxxx	cm ³ /rev	Dimension		Speed of rotation		Max pressure bar	Weight kg	Rotation Clockwise
		A	B	min. rpm	max. rpm			
0008	0.8	32.6	64.3	500	5000	280	1.05	
0012	1.2	33.4	65.8	500	5000	280	1.05	3309111395
0016	1.6	34.1	67.3	500	5000	280	1.05	3309111458
0021	2.1	34.9	68.9	500	4500	280	1.05	3309111459
0025	2.5	35.7	70.5	500	4500	280	1.15	3309111396
0033	3.3	37.2	73.5	500	4000	280	1.15	3309111397
0036	3.6	37.8	74.6	500	4000	260	1.15	3309111429
0043	4.3	39.2	77.5	500	4000	250	1.25	3309111398
0048	4.8	40.0	79.0	500	3800	230	1.35	3309111454
0058	5.8	41.9	82.8	500	3800	200	1.35	3309111430
0062	6.2	42.6	84.3	500	3500	180	1.45	
0079	7.9	45.8	90.6	500	3000	160	1.55	

PGP502AxxxxCV2P3XJ4J3B1B1

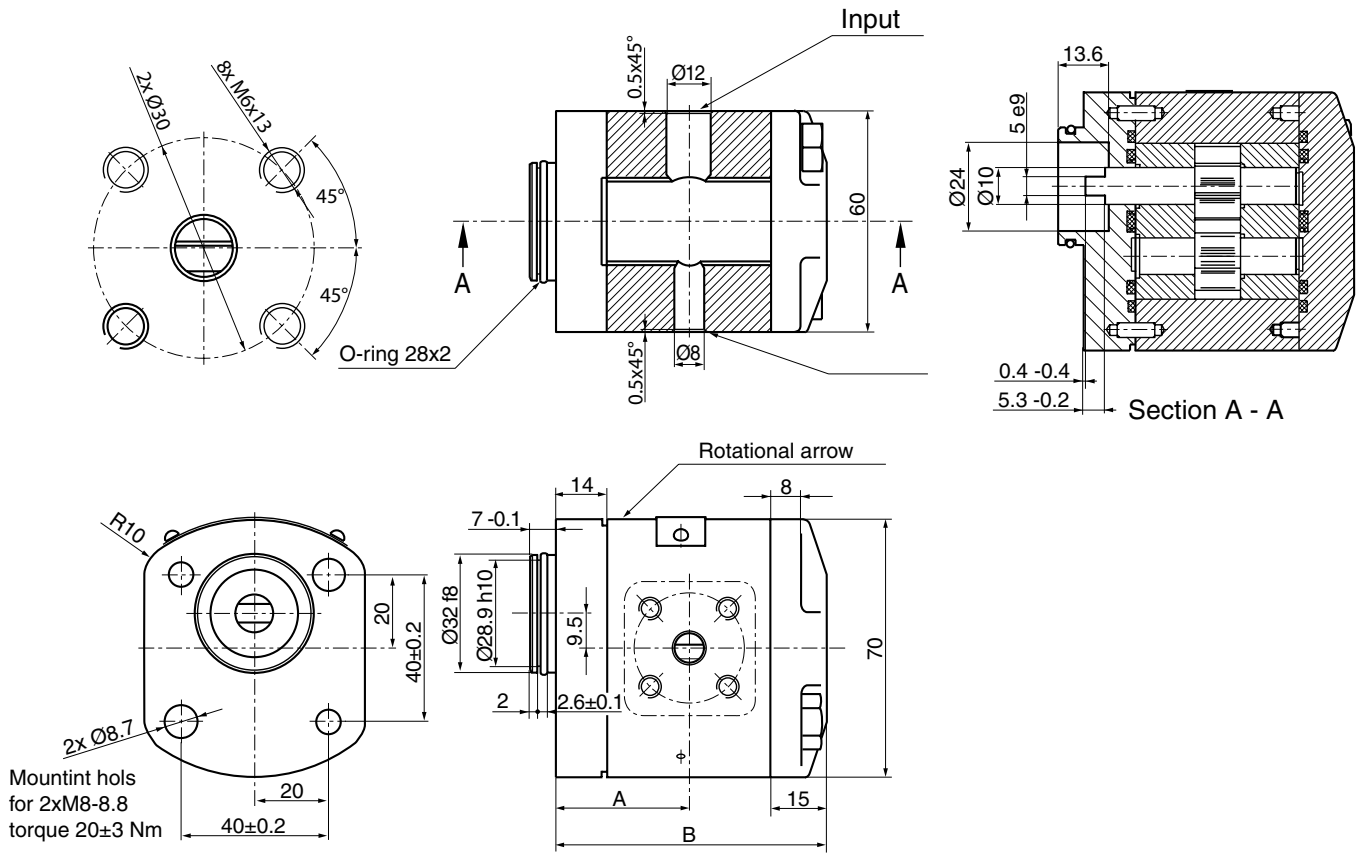

Displacement xxx	cm ³ /rev	Dimension		Speed of rotation		Max pressure bar	Weight kg	Rotation Clockwise
		A	B	min. rpm	max. rpm			
0008	0.8	32.6	64.3	500	5000	280	1.05	
0012	1.2	33.4	65.8	500	5000	280	1.05	3309111399
0016	1.6	34.1	67.3	500	5000	280	1.05	
0021	2.1	34.9	68.9	500	4500	280	1.05	3309111400
0025	2.5	35.7	70.5	500	4500	280	1.15	3309111476
0033	3.3	37.2	73.5	500	4000	280	1.15	3309111401
0036	3.6	37.8	74.6	500	4000	260	1.15	
0043	4.3	39.2	77.5	500	4000	250	1.25	3309111402
0048	4.8	40.0	79.0	500	3600	230	1.35	
0058	5.8	41.9	82.8	500	3000	200	1.35	
0062	6.2	42.6	84.3	500	2600	180	1.45	3309111331
0079	7.9	45.8	90.6	500	2200	140	1.55	3309111403

Germany		Code	TDN No	Code	TDN No	Code
FRONTFLANGE	502		511		517	
82,5-dia50,8 SAE "A-A" 2-bolt flange						
82,5-dia50,8 SAE "A-A" 2-bolt flange						
106,4-dia82,55 SAE "A" 2-bolt flange			334 5021 202	H2	333 5020 202	H2
SAE "A" 2-bolt flange - slotted			334 5021 213	H5		
146,1-dia101,6 SAE "B" 2-bolt flange			334 5021 203	H3	333 5020 203	H3
4bolt square fl, 50,8x50,8 dia 45,25						
4-bolt rectangular 52,2x72,0 dia. 25,4	187 1814	D1 - cw				
4-bolt rectangular 52,2x72,0 dia. 25,5	187 1872	D1 - ccw				
4-bolt rectangular 56,0x73,0 dia 30,0						
4-bolt rectangular 71,4x96,0 dia 36,47			334 5041 202	D3		
4-bolt rectangular 72,0x100,0 dia 80,0			334 5041 203	D4		
4-bolt rectangular 88,4x132,0 dia 99,94					333 5040 204	D5
4-bolt rectangular 98,4x128,2 dia. 50,77					333 5040 205	D7
thru bolt 40x40 dia 32,0 w/o lip seal	187 1805	P3 - cw	334 5050 201	Q1		
thru bolt 40x40 dia 32,0 w/o lip seal	187 1830	P3 - ccw	334 5051 201	Q2		
			334 5050 202	Q3		
			334 5051 202	Q4		
DRIVE SHAFT	502		511		517	
taper 1:8			334 19XX 601	S2	333 19XX 603	T1
taper 1:5			334 19XX 600	S1	333 19Xx 604	T2
SAE-A 9T 16/32P			334 12XX 200	A1		
SAE 19-4 11T 16/32P			334 12XX 303	C2		
SAE-B 13T 16/32P					333 12XX 400	D1 (w/o H2)
SAE-B 13T 16/32P					333 12XX 401	D1 (for H2)
SAE-A straight key			334 17XX 200	K1		
SAE 19-1 straight key			334 17XX 300	L6		
SAE-B straight key					333 17XX 400	M1 (w/o H2)
SAE-BB 15T					333 12XX 800	E1
SAE-BB straight key					333 17xx 800	M2 (w/o H2)
tang drive			334 14Xx 500	V5		
DRIVEN GEAR	502		511		517	
Standard			334 27XX 000		333 27XX 000	
internal splined (sealed sections)			334 26XX 004		333 26XX 001	
internal splined (unsealed sections)			334 26XX 010		333 26XX 010	
GEAR HOUSINGS	502		511		517	
			334 81XX 100		333 81XX 100	
CONNECTING SHAFTS	502		511		517	
			332 1133 001	511/511	324 1133 001	517/517
					333 1133 001	517/511
					324 1133 007	517/505
			334 1133 007 + 391 9997 058	511/502		
END COVERS	502		511		517	
			334 3000 100	B1B1	333 3000 100	B1B1
			332 3031 406	E5E3	333 3031 418	E6E5
			332 3031 312	D5D4	333 3031 319	D7D5
Pump incl. Relief valve			332 3030 087	R/V 3913681031	333 3030 904	R/V 3913681052
MID PLATES/ADAPTORS	502		511		517	
tandem units unsealed			391 2183 232	511/511	391 2183 238	517/517
Interframes			334 3040 100	511/502		
Interframes					333 3040 091	517/505
Interframes (sealed sections)					333 3040 084	517/511
Interframes (unsealed sections)					333 3040 088	517/511
tandem units sealed (both are needed)			334 5050 204+	511/511	333 5050 205+	517/517
			334 5051 205	511/511	333 5051 205	517/517
Screws			391 1425 XXX		391 1425 XXX	
			3911425767	stud 380 mm (8.8)	3911425761	stud 410 mm (10.9)

Germany		Drawing No	TDN No	Drawing No	TDN No	Drawing No
SHAFT SEAL	502		511		517	
PUMP STANDARD	391 2883 193		8301-019-00K		391 2883 058	
Pump FPM	391 2883 232		8301-119-00D		391 2883 104	
MOTOR STANDARD	391 2883 193		8339-019-00S		391 2883 119	
MOTOR FPM	391 2883 235		8301-020-00M		391 2883 119	
PUMP/MOTOR CONTINENTAL SHAFT			391 2883 197		391 2883 215	
Pump standard large size shaft			9352-061-00T	C1,C2,F2,L5,L6,		
BUSHING BLOCK	502		511		517	
PUMP STANDARD			8898-207-00U		391 2185 093	
MOTOR STANDARD			391 2185 133		391 2185 118	
PUMP STANDARD with seals			73340:4108829			
MOTOR STANDARD with seals			391 1822 719			
SEALS	502		511		517	
SECTION SEAL			9313-145-00B		391 2882 148	
PUMP BACK-UP			8611-015-000		391 2882 162	
CHANNEL			8611-016-00R		391 2882 161	
MOTOR (bi-rot.) BACK-UP			8301-015-006		391 2882 181	
CHANNEL			8301-016-0AB		391 2882 182	
CHANNEL			8301-016-0B9			
SEAL KITS	502		511		517	
single Pump standard	391 1832 810		8611-023-00N		391 1822 071	
single Pump FPM	391 1832 811		8611-023-00V		391 1832 772	
double pump standard			8677-023-00E		392 1822 072	
single split gear pump			8801-023-00N			
motor bi rotat. standard	391 1832 812		8301-023-00N		391 1801 336	
motor bi rotat. Viton			8301-023-00M			
ROLLER BEARING			391 0381 126	F3, F4, F5, L2		
			391 0381 116	L7		
OUTBOARD BEARING	502		511		517	
			391 1822 365	S8F4		
			391 1822 471	D1L7		
			391 1822 586	K7L2		
					391 1842 243	M2L3
SNAP RING			9211-323-00B			
DOWEL PINS			391 2080 078	short	391 2080 080	short
			391 2080 079	long	391 2080 081	long
FLAT SEAL SAE-A			391 2883 187		391 2883 187	
SIZES AND PRESSURES	502		511		517	
	CC/REV	BAR	CC/REV	BAR	CC/REV	BAR
	0,80	280	4,00	250	14,00	250
	1,20	280	6,00	250	16,00	250
	1,60	280	8,00	250	19,00	250
	2,10	280	10,00	250	23,00	250
	2,50	280	11,00	250	25,00	250
	3,30	280	14,00	250	28,00	250
	3,60	260	16,00	250	33,00	250
	4,30	250	19,00	250	38,00	250
	4,80	230	23,00	225	44,00	220
	5,80	200	27,00	190	52,00	200
	6,20	180	31,00	165	58,00	180
	7,90	160	33,00	155	70,00	160

Shaft loads PGP/PGM500

Code	Description	Type	Torque rating [Nm]			
			PGP/PGM502	PGP/PGM505	PGP/PGM511	PGP/PGM517
H1	Ø10.0, 3.0 key, no thread, 36L	parallel	30	—	—	—
P2	Ø9.95, 8.8L, 2.4 key, M6	taper 1:8	30	—	—	—
V1	5 x 6.5 long shaft w/o coupling	tang drive	20	—	—	—
V2	5 x 4.5 short shaft w/o coupling	tang drive	20	—	—	—
A1	9T, 16/32DP, 32L, SAE "A"	splined	—	108	—	—
J1	Ø12.7, 3.2 key, no thread, 38L	parallel	—	43	—	—
K1	Ø15.88, 4.0 key, no thread, 32L, SAE "A"	parallel	—	85	—	—
Q2	Ø14.25, 5.5L, 3.0 key, M10x1	taper 1:8	—	68	—	—
A1	9T, 16/32DP, 32L, SAE "A"	splined	—	—	86	—
C1	11T, 16/32DP, 38.2L, SAE 19-4	splined	—	—	166	—
F1	9T, B17x14.23L, DIN 5482	splined	—	—	101	—
K1	Ø15.88, 4.0 key, no thread, 32L, SAE "A"	parallel	—	—	75	—
L6	Ø19.05, 4.8 key, no thread, 32L, SAE 19-1	parallel	—	—	145	—
S1	Ø17.0, 7.7L, 3.0 key, M12x1.5	taper 1:5	—	—	193	—
S2	Ø16.65, 12.0L, 3.2 key, M12x1.5	taper 1:8	—	—	198	—
S4	Ø16.65, 12.0L, 4.0 key, M12x1.5	taper 1:8	—	—	198	—
D1	13T, 16/32DP, 41.2L, SAE "B"	splined	—	—	—	345
M1	Ø22.2, 6.3 key, no thread, 41.2L, SAE "B"	parallel	—	—	—	251
M2	Ø25.4, 6.3 key, no thread, 46L, SAE "B-B"	parallel	—	—	—	395
T1	Ø21.59, 11.2L, 4.0 key, M14x1.5	taper 1:8	—	—	—	250
	Connecting shaft for multiple units		20	36	110	228

Formula to calculate shaft load

$$\text{Torque [Nm]} = \frac{\text{Displacement [cm}^3/\text{rev]} \cdot \text{Pressure [bar]}}{57.2}$$

Hydraulic fluids

Type	Fluid composition	Max. working pressure [bar]	Max. speed [min-1]	Temperature	Seal
Hydraulic fluid	Mineral oil based on hydraulic fluid acc. to ISO/DIN	See table drawings	See table drawings	-15 ... +80 °C -15 ... +120 °C	NBR FPM
HFB	Water-in-oil emulsion 40/60	140	1500	+2 ... +65 °C	NBR
HFC *	Water-glycol 40/60	140	1500	-15 ... +65 °C	NBR
HFD	Phosphate ester	140	1500	-10 ... +80 °C	FPM

* to be used with cast iron pumps/motors only

Parker does not give an explicit recommendation for certain fluid product, fluid brand or fluid manufacturer
The risk of using different kind of fluids has to be taken by the customer.

Flanges for suction and discharge ports

Please refer to Parker Bulletin 4040/UK.



WARNING – USER RESPONSIBILITY

FAILURE OR IMPROPER SELECTION OR IMPROPER USE OF THE PRODUCTS DESCRIBED HEREIN OR RELATED ITEMS CAN CAUSE DEATH, PERSONAL INJURY AND PROPERTY DAMAGE.

This document and other information from Parker-Hannifin Corporation, its subsidiaries and authorized distributors provide product or system options for further investigation by users having technical expertise.

The user, through its own analysis and testing, is solely responsible for making the final selection of the system and components and assuring that all performance, endurance, maintenance, safety and warning requirements of the application are met. The user must analyze all aspects of the application, follow applicable industry standards, and follow the information concerning the product in the current product catalog and in any other materials provided from Parker or its subsidiaries or authorized distributors.

To the extent that Parker or its subsidiaries or authorized distributors provide component or system options based upon data or specifications provided by the user, the user is responsible for determining that such data and specifications are suitable and sufficient for all applications and reasonably foreseeable uses of the components or systems.

Offer of Sale

Please contact your Parker representation for a detailed "Offer of Sale".

Parker Worldwide

Europe, Middle East, Africa

AE – United Arab Emirates, Dubai

Tel: +971 4 8127100
parker.me@parker.com

AT – Austria, Wiener Neustadt
Tel: +43 (0)2622 23501-0
parker.austria@parker.com

AT – Eastern Europe, Wiener Neustadt
Tel: +43 (0)2622 23501 900
parker.easteurope@parker.com

AZ – Azerbaijan, Baku
Tel: +994 50 22 33 458
parker.azerbaijan@parker.com

BE/LU – Belgium, Nivelles
Tel: +32 (0)67 280 900
parker.belgium@parker.com

BG – Bulgaria, Sofia
Tel: +359 2 980 1344
parker.bulgaria@parker.com

BY – Belarus, Minsk
Tel: +48 (0)22 573 24 00
parker.poland@parker.com

CH – Switzerland, Etoy
Tel: +41 (0)21 821 87 00
parker.switzerland@parker.com

CZ – Czech Republic, Klecany
Tel: +420 284 083 111
parker.czechrepublic@parker.com

DE – Germany, Kaarst
Tel: +49 (0)2131 4016 0
parker.germany@parker.com

DK – Denmark, Ballerup
Tel: +45 43 56 04 00
parker.denmark@parker.com

ES – Spain, Madrid
Tel: +34 902 330 001
parker.spain@parker.com

FI – Finland, Vantaa
Tel: +358 (0)20 753 2500
parker.finland@parker.com

FR – France, Contamine s/Arve
Tel: +33 (0)4 50 25 80 25
parker.france@parker.com

GR – Greece, Athens
Tel: +30 210 933 6450
parker.greece@parker.com

HU – Hungary, Budaörs
Tel: +36 23 885 470
parker.hungary@parker.com

IE – Ireland, Dublin
Tel: +353 (0)1 466 6370
parker.ireland@parker.com

IT – Italy, Corsico (MI)
Tel: +39 02 45 19 21
parker.italy@parker.com

KZ – Kazakhstan, Almaty
Tel: +7 7273 561 000
parker.easteurope@parker.com

NL – The Netherlands, Oldenzaal
Tel: +31 (0)541 585 000
parker.nl@parker.com

NO – Norway, Asker
Tel: +47 66 75 34 00
parker.norway@parker.com

PL – Poland, Warsaw
Tel: +48 (0)22 573 24 00
parker.poland@parker.com

PT – Portugal
Tel: +351 22 999 7360
parker.portugal@parker.com

RO – Romania, Bucharest
Tel: +40 21 252 1382
parker.romania@parker.com

RU – Russia, Moscow
Tel: +7 495 645-2156
parker.russia@parker.com

SE – Sweden, Spånga
Tel: +46 (0)8 59 79 50 00
parker.sweden@parker.com

SK – Slovakia, Banská Bystrica
Tel: +421 484 162 252
parker.slovakia@parker.com

SL – Slovenia, Novo Mesto
Tel: +386 7 337 6650
parker.slovenia@parker.com

TR – Turkey, Istanbul
Tel: +90 216 4997081
parker.turkey@parker.com

UA – Ukraine, Kiev
Tel: +48 (0)22 573 24 00
parker.poland@parker.com

UK – United Kingdom, Warwick
Tel: +44 (0)1926 317 878
parker.uk@parker.com

ZA – South Africa, Kempton Park
Tel: +27 (0)11 961 0700
parker.southafrica@parker.com

North America

CA – Canada, Milton, Ontario
Tel: +1 905 693 3000

US – USA, Cleveland
(industrial)
Tel: +1 216 896 3000

US – USA, Elk Grove Village
(mobile)
Tel: +1 847 258 6200

Asia Pacific

AU – Australia, Castle Hill
Tel: +61 (0)2-9634 7777

CN – China, Shanghai
Tel: +86 21 2899 5000

HK – Hong Kong
Tel: +852 2428 8008

ID – Indonesia, Tangerang
Tel: +62 21 7588 1906

IN – India, Mumbai
Tel: +91 22 6513 7081-85

JP – Japan, Fujisawa
Tel: +81 (0)4 6635 3050

KR – South Korea, Seoul
Tel: +82 2 559 0400

MY – Malaysia, Shah Alam
Tel: +60 3 7849 0800

NZ – New Zealand, Mt Wellington
Tel: +64 9 574 1744

SG – Singapore
Tel: +65 6887 6300

TH – Thailand, Bangkok
Tel: +662 186 7000

TW – Taiwan, New Taipei City
Tel: +886 2 2298 8987

VN – Vietnam, Ho Chi Minh City
Tel: +84 8 3999 1600

South America

AR – Argentina, Buenos Aires
Tel: +54 3327 44 4129

BR – Brazil, Cachoeirinha RS
Tel: +55 51 3470 9144

CL – Chile, Santiago
Tel: +56 2 623 1216

MX – Mexico, Toluca
Tel: +52 72 2275 4200

Ed. 2016-04-04

EMEA Product Information Centre

Free phone: 00 800 27 27 5374

(from AT, BE, CH, CZ, DE, DK, EE, ES, FI, FR, IE, IL, IS, IT, LU, MT, NL, NO, PL, PT, RU, SE, SK, UK, ZA)

US Product Information Centre

Toll-free number: 1-800-27 27 537

www.parker.com/pmde

