



# Air Driven, High Pressure Liquid Pumps

## Product Catalog

Catalog: 02-9326BE

April 2022

aerospace  
climate control  
electromechanical  
filtration  
fluid & gas handling  
hydraulics  
pneumatics  
process control  
sealing & shielding



ENGINEERING YOUR SUCCESS.

# Table of Contents

Introduction .....	2
Pump Series Models .....	3
Drive Types .....	3
Quick Reference Guide .....	4
Pump Operation .....	5
Air Drive Section .....	5
Typical Pump Cut-away .....	6
Pump Special Features .....	7
ASL Series Pump .....	8
ACHL Series Pump .....	13
AFL Series Pump .....	16
AHL Series Pump .....	19

## Introduction

Parker Autoclave Engineers has always been a large user of Air-over-Liquid pump technology and has a lifetime of experience using all variety of pumps in many different configurations. We have used this experience to develop a best-in-breed line of air-driven, high pressure pumps that are efficient to operate, simple in design, and will stand the test of time. Compared to other types of hydraulic pumps, they provide cost effective and energy saving benefits for many applications in the Oil and Gas, Chemical, Industrial and Research industries.

These pumps convert simple air pressure into high and ultra-high liquid pressures by utilizing a large area piston on the air side to move a small area plunger to compress the liquid into very high hydraulic pressures - as high as 60,000 psi (4137 bar). Some designs are for economy, some for manual use, some for low-flow & high pressure, some for high flow & medium pressure. Pumps like these are perfect for product testing, valve actuation, chemical injection and other applications that require intense pressure. When used in conjunction with a Hydraulic Intensifier (another PAE product) pressures to 150,000 psi (10,000 bar) are normal.

Parker Autoclave Engineers has been making pressure and corrosion test systems as well as high pressure laboratory reaction vessels for over 70 years.

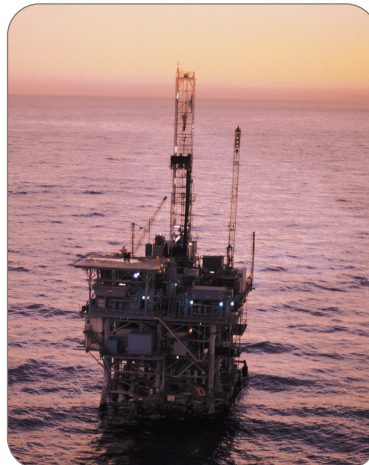

## Pump Series Models



### ASL Series:

- Standard Liquid Pump
- Pressures up to 60,000 psi (4137 bar)
- 6 inches in diameter air piston
- Broad range of ratios
- Single and Double Piston



### ACHL Series:

- ACL Series Pump with hand lever - Air or Manually Driven
- Pressures up to 31,900 psi (2199 bar)
- Precise Pressure control operation, pump is spring returned
- 3 inches in diameter air piston



### AFL Series:

- High Flow, High Pressure
- Pressures up to 5,000 psi (1035 bar)
- Flow up to 6.8 gpm (25 lpm)
- Dual Acting

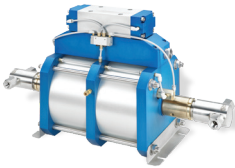

### AHL Series:

- High Flow up to 7.6 gpm (29 lpm)
- Pressures up to 22,500 psi (917 bar)
- Approximately 10 inch diameter air piston
- Dual Acting

## Drive Types

<b>Pump Model</b>				
<b>Catalog Number Suffix</b>	<b>-01</b>	<b>-02</b>	<b>-1D</b>	<b>-2D</b>
<b>Description</b>	Single Acting Single Piston	Single Acting Double Piston	Double Acting Single Piston	Double Acting Double Piston

Catalog Number Example: ASL150-01

## Quick Reference Guide

Pump Type	Catalog Number	Pressure Ratio	Maximum Rated Outlet Pressure PSI (bar)	Displacement Per Cycle .in <sup>3</sup> (cm <sup>3</sup> )	Max. Flow GPM	Liquid Connections	
						Inlet	Outlet

ASL Series - Air Driven Standard Size Liquid Pumps							
Prefill/Flushing	ASL10-01	1:11	1,600 (110)	5.22 (85.5)	5.0	1" FNPT	1/2" FNPT
Low Pressure	ASL25-01	1:28	4,000 (276)	2.10 (34.4)	2.3	1/2" FNPT	1/2" FNPT
Low Pressure	ASL35-01	1:39	5,600 (386)	1.50 (24.64)	1.3	1/2" FNPT	1/2" FNPT
Test Pump	ASL60-01	1:70	10,000 (689)	0.84 (13.8)	.79	1/2" FNPT	1/2" FNPT
Test Pump	ASL100-01	1:113	15,000 (1,034)	0.52 (8.5)	.48	1/2" FNPT	1/2" FNPT
Test Pump	ASL150-01	1:150	21,500 (1,482)	0.39 (6.4)	.36	1/2" FNPT	1/4" F250C
Test Pump	ASL250-01	1:265	38,400 (2,648)	0.22 (3.6)	.21	1/2" FNPT	1/4" F250C
Test Pump	ASL400-01	1:398	57,700 (3,978)	0.14 (2.3)	.14	1/2" FNPT	1/4" F250C
Test Pump	ASL35-02	1:78	11,200 (772)	1.50 (24.64)	1.05	1/2" FNPT	1/2" FNPT
Test Pump	ASL60-02	1:140	20,000 (1,379)	0.84 (13.8)	.63	1/2" FNPT	9/16" SF562CX
Test Pump	ASL100-02	1:226	31,000 (2,137)	0.52 (8.5)	.37	1/2" FNPT	1/4" F250C
Test Pump	ASL150-02	1:300	43,000 (2,965)	0.39 (6.4)	.28	1/2" FNPT	1/4" F250C
Test Pump	ASL400-02	1:796	60,000 (4,137)	0.14 (2.3)	.11	1/2" FNPT	1/4" F250C
ACHL Series							
Compact/ Manual Pumps	ACHL72-01	1:84	12,500 (862)	0.09 (1.47)	.17	3/8" FNPT	1/4" F250C
	ACHL189-01	1:213	31,900 (2,199)	0.035 (0.57)	.19	3/8" FNPT	1/4" F250C
AHL Series							
Chemical Injection	AHL33-2D	1:67	6,700 (462)	15.3 (250.7)	7.6	1" FNPT	1/2" FNPT
	AHL66-2D	1:133	13,300 (917)	7.8 (127.8)	3.6	1/2" FNPT	1/2" FNPT
	AHL118-2D	1:239	22,500 (1551)	4.4 (72.1)	2.3	1/2" FNPT	9/16" SF562CX
AFL Series							
High Flow Pumps	AFL35-1D	1:39	5,600 (386)	6.02 (98.7)	6.9	1" FNPT	9/16" SF562CX
	AFL60-1D	1:70	10,000 (690)	3.40 (55.7)	3.9	1" FNPT	9/16" SF562CX
	AFL100-1D	1:113	15,000 (1034)	2.30 (37.7)	2.9	1" FNPT	9/16" SF562CX

## Pump Operation

### Piston to Plunger Ratio

- Compressed air is used to produce hydraulic pressure
- Works on differential surface area between the large air piston and smaller hydraulic plunger
- Differential is represented by the pressure ratio of the pump

Pressure Ratio = Area of Air Piston ÷ Area of Hydraulic Plunger

- The higher the pressure ratio, the higher the output hydraulic pressure

Pressure Output = Pressure Ratio x Air Drive Pressure

- When air is applied to the pump it will cycle until the forces on the air piston equals the forces on the hydraulic plunger. This is the stall pressure.
- Pump will automatically restart if there is a drop in hydraulic pressure or an increase in air drive pressure.
- Double air pistons available which will double the pressure ratio because you have twice the air piston area acting on the same hydraulic plunger area.

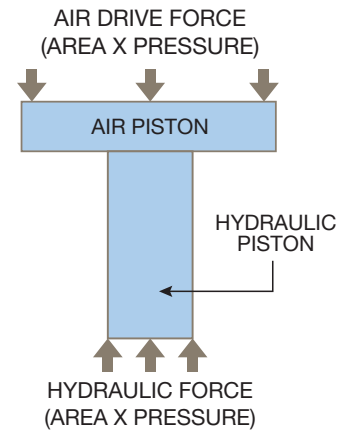

## Air Drive Section

- Compressed air is used to produce hydraulic pressure
- Works on differential surface area between the large air piston and smaller hydraulic plunger
- Differential is represented by the pressure ratio of the pump

### Section 1

- Air pilot operated spool provides automatic cycling of air from one side of the piston to the other
- At the end of each stroke, the air piston activates a pilot valve that will cause the spool to shift

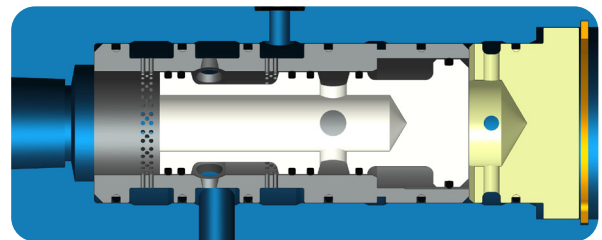

### Section 2

- The spool shifting will supply air to one side of the piston while venting the other side of the piston
- This alternating action continues until the pump reaches its stall pressure

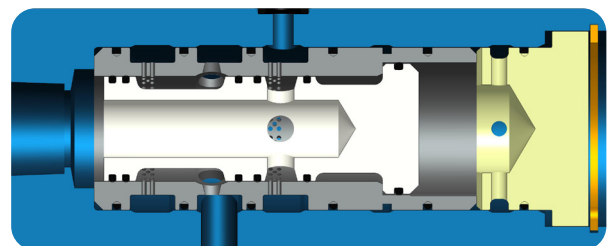

## Typical Pump Cut-Away

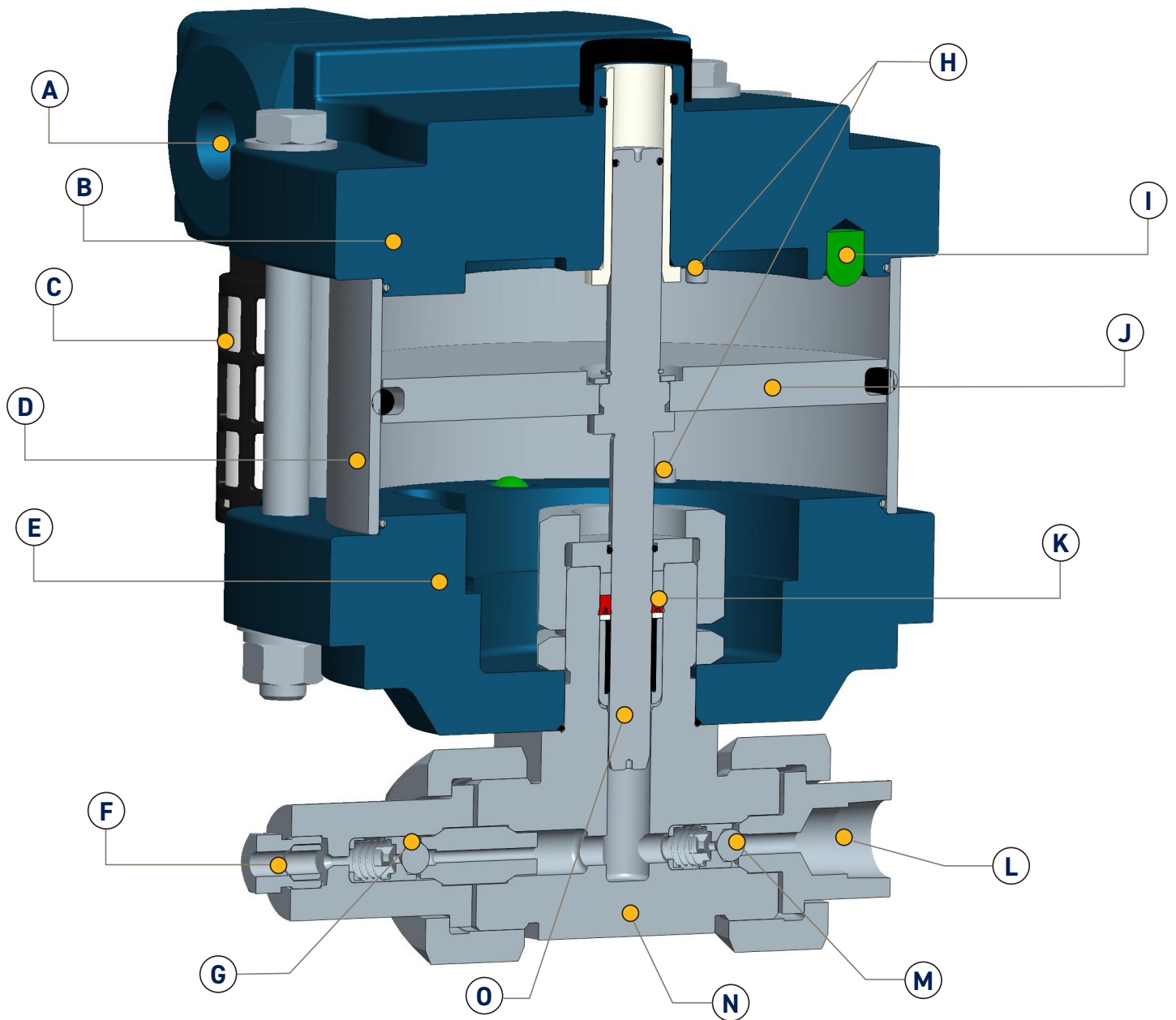

	Description
A	Air Inlet
B	Top End Cap
C	Air Muffler
D	Air Cylinder
E	Bottom End Cap
F	High Pressure Outlet Connection
G	Outlet Check Valve
H	Pilot Valve

	Description
I	Air Piston Bumper
J	Air Piston
K	High Pressure Seal Assembly
L	Liquid Inlet Connection
M	Inlet Check Valve
N	Pump Head Body
O	Hydraulic Plunger

## Pump Special Features & Benefits

- All Aluminum parts machined from high quality bar stock, not cast aluminum components
- Anodizing with special sealing technique to provide better protection from harsh environments
- Muffler specified to give a great combination of high flow and low noise
- Rubber bumpers in end caps to reduce noise of operation
- Latest lubrication technology provides long seal service life and improves pump efficiency and performance
- No lubricator required for air drive source
- Stainless steel tie-rods and hardware
- Stainless plunger coated with a proprietary multi-layer carbon based coating with diamond like carbon exterior layer:
  - High hardness (3 times harder than Stellite)
  - Inert, it has superior chemical compatibility and corrosion resistance
  - Low friction that limits seal wear and increases efficiency (coefficient of friction equal to or less than PTFE)
  - Tough coating that provides long plunger cycle life.
- Pressure head specially designed and engineered for high cycle life
- Spring energized U-cup seal provides better sealing performance at wide ranges of pressures
- Extended service life check valves with Ceramic balls for high pressure applications

# ASL SERIES Single-Acting, Single or Double Piston Air Drive



## Features:

- Pressure Ranges from 1,600 to 60,000 psi (110 to 4100 bar) max
- Operating Temperature Range: 0° to 140°F (-18° to 60°C)
- Pressure Head Material: 15-5 PH Stainless Steel
- Plunger: Stainless Steel, coated with proprietary multi-layer carbon for long life
- Liquid Side Material: All Stainless Steel Construction
- Air Side Material: Anodized Aluminum

## Technical Data:

- Liquid Connections: Side Inlet Only – see chart (page 9)
- Isolation Chamber: Only available on ASL400-02 pump
- Displacement per stroke: See chart (page 9)
- Liquid Seals:
  - ASL10 to ASL35 = UHMWPE U-Cup and FKM Orings (PV option)
  - ASL60 to ASL400 – UHMWPE U-Cup w/Elgiloy Spring Energizer
- Air Drive Pressure Range: 15-150 psi (1-10 bar) \* See Note
- Main Air Inlet: ½" FNPT (Regulated)
- Pilot Air Inlet: 1/8" FNPT (unregulated)
- Max Air Consumption: 70 SCFM @ 90 psi (no pressure)
- Pre-Lubricated Piston at Factory
- Air Seals: Buna-N

**Note:** \*Maximum air drive pressure is limited by maximum pressure shown in chart on Page 9.



# ASL Pump Part Number Matrix

For complete information on available pump options, contact Parker Autoclave Engineers.

Typical catalog number: **ASL25-01SNPV**

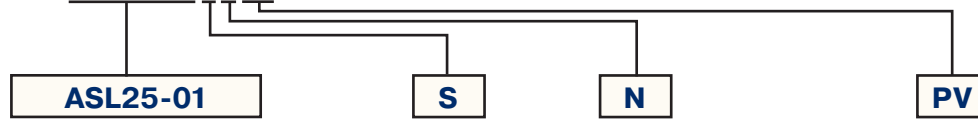

Pump Type / Size / Ratio	Liquid Inlet Location	Isolation Chamber	Liquid Seal Materials
<b>ASL</b> = • Standard Liquid High Flow, High Pressure Pump • Air-to-Liquid Pressure Ratio: <b>Single Piston</b> ASL10-01 - 1:11 ASL25-01 - 1:28 ASL35-01 - 1:39 ASL60-01 - 1:70 ASL100-01 - 1:113 ASL150-01 - 1:150 ASL250-01 - 1:265 ASL400-01 - 1:398 <b>Double Piston</b> N/A N/A ASL35-02 - 1:78 ASL60-02 - 1:140 ASL100-02 - 1:226 ASL150-02 - 1:300 N/A ASL400-02 - 1:796*	<b>S</b> = Side	<b>N</b> = None <b>*C</b> = Standard (ASL400-02 only)	<b>PV</b> = UHMWPE U-Cup and FKM O-Rings (ASL10 to ASL35 Pumps Only) <b>P</b> = UHMWPE U-Cup with Elgiloy Spring Energizer (All other Pump Series)

**Note:** Individual Pump Specifications can be found at [www.Autoclave.com](http://www.Autoclave.com).

## Reference Guide

Catalog Number	Pressure Ratio	Maximum Rated Outlet Pressure PSI (bar)	GPM Displacement Per Cycle .in <sup>3</sup> (cm <sup>3</sup> )	Liquid Connections	
				Inlet	Outlet
ASL10-01SNXX	1:11	1,600 (110)	5.22 (85.5)	1" FNPT	1/2" FNPT
ASL25-01SNXX	1:28	4,000 (276)	2.10 (34.4)	1/2" FNPT	1/2" FNPT
ASL35-01SNXX	1:39	5,600 (386)	1.50 (24.64)	1/2" FNPT	1/2" FNPT
ASL60-01SNXX	1:70	10,000 (689)	0.84 (13.8)	1/2" FNPT	1/2" FNPT
ASL100-01SNXX	1:113	15,000 (1,034)	0.52 (8.5)	1/2" FNPT	1/2" FNPT
ASL150-01SNXX	1:150	21,500 (1,482)	0.39 (6.4)	1/2" FNPT	1/4" F250C
ASL250-01SNXX	1:265	38,400 (2,648)	0.22 (3.6)	1/2" FNPT	1/4" F250C
ASL400-01SCXX	1:398	57,700 (3,978)	0.14 (2.3)	1/2" FNPT	1/4" F250C
ASL35-02SNXX	1:78	11,200 (772)	1.50 (24.64)	1/2" FNPT	1/2" FNPT
ASL60-02SNXX	1:140	20,000 (1,379)	0.84 (13.8)	1/2" FNPT	9/16" SF562CX
ASL100-02SNXX	1:226	31,000 (2,137)	0.52 (8.5)	1/2" FNPT	1/4" F250C
ASL150-02SNXX	1:300	43,000 (2,965)	0.39 (6.4)	1/2" FNPT	1/4" F250C
ASL400-02SCXX	1:796	60,000 (4,137)	0.14 (2.3)	1/2" FNPT	1/4" F250C

## Air Drive Connection

All ASL Series Pumps have a 1/2" FNPT regulated main air drive supply connection and utilize a 1/8" FNPT pilot port connection for remote start/stop operation. It is recommended to operate the pilot port at a higher air pressure unregulated than the main air drive supply pressure for proper function.

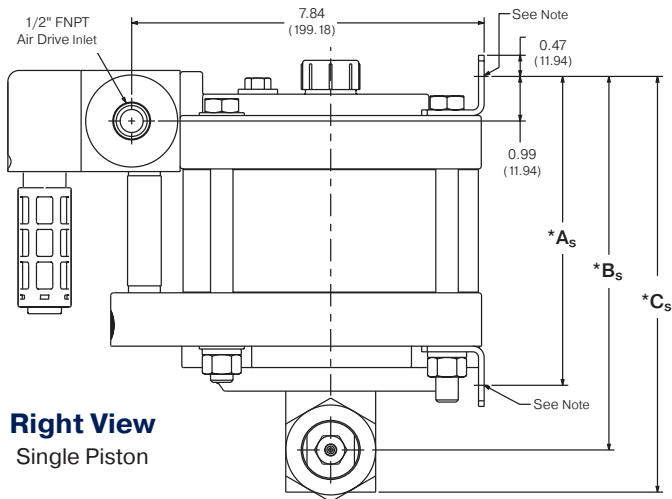

\*See following page for product dimensions.

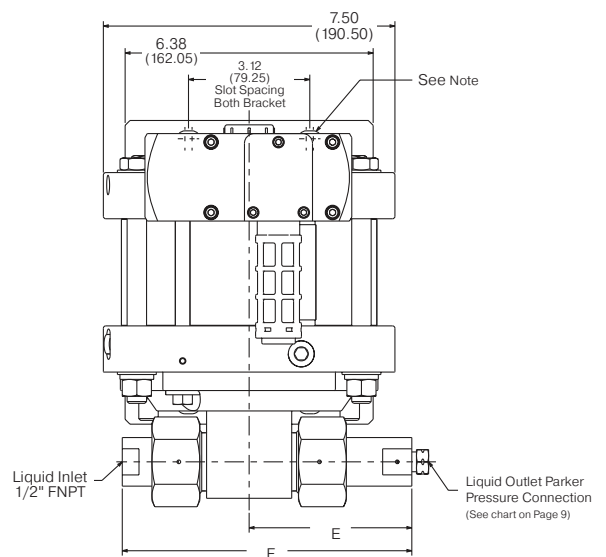
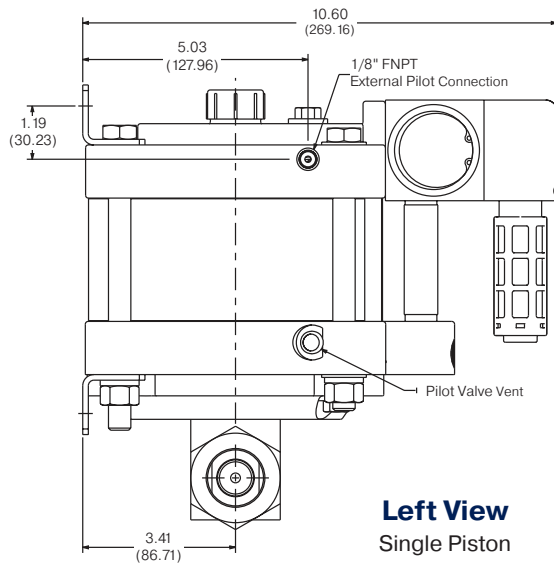
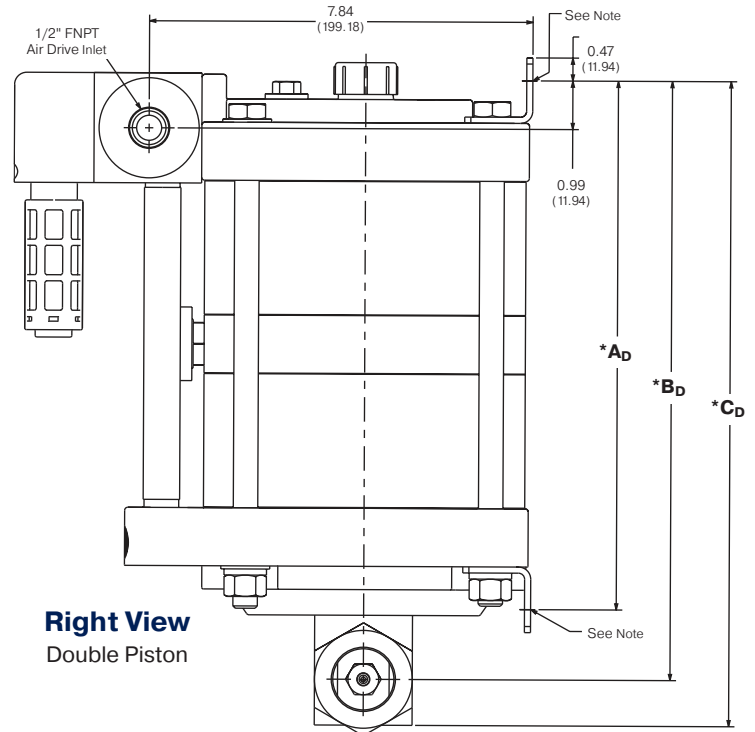

**Front View**  
Single Piston

**Note:**

- Each mounting bracket includes (2) x 11/32" (8.73) slots for 5/16" bolts.
- All dimensions are for reference only and are subject to change without notice.
- Primary dimensions: Inches, Secondary Dimensions: (Millimeters)

## ASL Series: Dimensions

Catalog Number	A <sub>S</sub>	B <sub>S</sub>	C <sub>S</sub>
<b>Single Piston Air Drive</b>			
ASL10-01	6.87 (175)	8.25 (210)	9.83 (250)
ASL25-01	6.87 (175)	8.25 (210)	9.83 (250)
ASL35-01	6.87 (175)	8.25 (210)	9.83 (250)
ASL60-01	6.87 (175)	8.31 (211)	9.25 (235)
ASL100-01	6.87 (175)	8.31 (211)	9.25 (235)
ASL150-01	6.87 (175)	8.31 (211)	9.25 (235)
ASL250-01	6.87 (175)	8.31 (211)	9.25 (235)
ASL400-01	6.87 (175)	8.37 (213)	9.39 (239)

Catalog Number	A <sub>D</sub>	B <sub>D</sub>	C <sub>D</sub>
<b>Double Piston Air Drive</b>			
ASL35-02	10.81 (275)	12.19 (310)	13.77 (350)
ASL60-02	10.81 (275)	12.25 (311)	13.19 (335)
ASL100-02	10.81 (275)	12.25 (311)	13.19 (335)
ASL150-02	10.81 (275)	12.25 (311)	13.19 (335)
ASL400-02	10.81 (275)	12.30 (312)	13.32 (338)

**Note:**

Each mounting bracket includes two (2) x 13/32" (10.32) slots for 3/8" bolts. Bottom inlet pump head and side inlet pump head are mutually exclusive. All dimensions are for reference only and are subject to change without notice.

Primary Dimensions: Inches  
 Secondary Dimensions: (Millimeters)

## Flow Rate Table: Air Drive Pressure (psi) vs. Outlet Pressure (psi)

Catalog Number	Air Drive Pressure (psi)	Outlet Pressure (psi)												in <sup>3</sup> / min.
		0	500	1,500	3,000	5,000	7,500	10,000	15,000	25,000	40,000	55,000		
ASL10-01	60	1277	489											
	90	305	826											
	120	1360	925											
ASL25-01	60	508	342	127										
	90	520	387	303										
	120	543	427	360	202									
ASL35-01	60	315	273	121										
	90	322	291	211	58									
	120	328	302	250	157									
ASL60-01	60	168	155	125	79									
	90	175	161	134	106	63								
	120	182	167	140	118	94	45							
ASL100-01	60	104	99	88	70	46								
	90	108	103	92	78	65	44	11						
	120	112	106	95	83	72	60	47						
ASL150-01	60	81	79	76	66	49	19							
	90	83	82	80	75	67	53	35						
	120	84	83	82	78	73	66	55	25					
ASL250-01	60	46	45	44	42	37	26	20	2					
	90	47	46	45	44	43	40	36	26					
	120	48	47	47	46	45	43	41	34	17				
ASL400-01	60	39	38	37	36	33	29	23	10					
	90	40	39	38	38	37	35	32	26	8				
	120	41	40	39	38	38	37	36	32	21				
ASL35-02	60	240	230	210	115									
	90	242	232	225	190	115								
	120	245	235	230	210	170	95							
ASL60-02	60	150	148	145	120	70	2							
	90	155	152	147	136	117	80	33						
	120	157	154	152	145	133	112	82	8					
ASL100-02	60	86	84	82	77	72	53	30						
	90	87	86	84	82	82	70	61	36					
	120	89	88	86	84	84	77	72	57	13				
ASL150-02	60	64	64	63	60	57	50	38	14					
	90	65	65	64	62	60	57	53	41	9				
	120	66	66	65	64	63	61	58	51	32				
ASL400-02	60	31	31	30	30	29	29	28	26	16				
	90	31	31	31	30	30	30	29	27	23	14	2		
	120	31	31	31	31	30	30	30	29	27	21	14		

# ACHL SERIES Single-Acting, Single Air Drive with Hand Lever



## Manual Operation

Air Driven Pump includes Hand Lever for manual operation or precise pressure control, remote locations, or emergency back-up.

## Features:

- Pressure Ranges from 12,500 (860 bar) or 31,900 psi (2200 bar) maximum
- Operating Temperature Range: 0° to 140°F (-18° to 60°C)
- Liquid Side Material: All Stainless Steel Construction
- Air Side Material: Anodized Aluminum

## Technical Data:

- Liquid Connections: Side Inlet Only – see chart (page 14)
- Displacement per stroke: See chart (page 14)
- Liquid Seals: UHMWPE U-Cup w/Elgiloy Spring Energizer
- Air Drive Pressure Range: 15-150 psi (1-10 bar) \* See Note
- Main Air Inlet: 1/4" FNPT (Regulated)
- Exhaust port (muffler removed) 1/4" FNPT
- Air Seals: Buna-N
- Pre-lubricated at Factory

**Note:** \*Maximum air drive pressure is limited by maximum pressure, see rating show above.

# ACHL Pump Part Number Matrix

Typical catalog number: **ACHL72-01SNP**

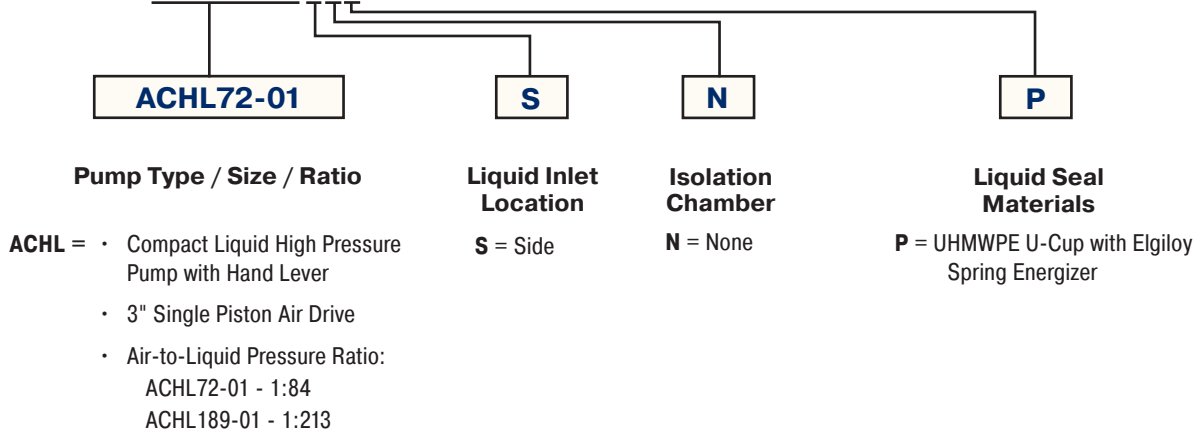

**Note:** Individual Pump Specifications can be found at [www.Autoclave.com](http://www.Autoclave.com).

## Reference Guide

Catalog Number	Pressure Ratio	Maximum Rated Outlet Pressure PSI (bar)	Displacement Per Cycle .in <sup>3</sup> (cm <sup>3</sup> )	Liquid Connections	
				Inlet	Outlet
ACHL72-01SNX	1:84	12,500 (862)	0.09 (1.47)	3/8" FNPT	1/4" F250C
ACHL189-01SNX	1:213	31,900 (2,199)	0.035 (0.57)	3/8" FNPT	1/4" F250C

## Flow Rate Table: Air Drive Pressure (psi) vs. Outlet Pressure (psi)

Catalog Number	Air Drive Pressure (psi)	Outlet Pressure (psi)											in <sup>3</sup> /min.
		0	500	1,500	3,000	5,000	7,500	10,000	15,000	25,000	40,000	55,000	
ACHL72-01SNX	60	42	32	17	9	1							
	90	42	34	25	18	7	1						
	120	43	35	29	24	17	7	2					
ACHL189-01SNX	60	15	15	15	15	14	13	8					
	90	15	15	15	15	15	13	11	7				
	120	15	15	15	15	15	13	12	8	1			

# Air Drive Connection

All ACHL Series Pumps have a 1/4" FNPT regulated main air drive supply connection

**Left View**

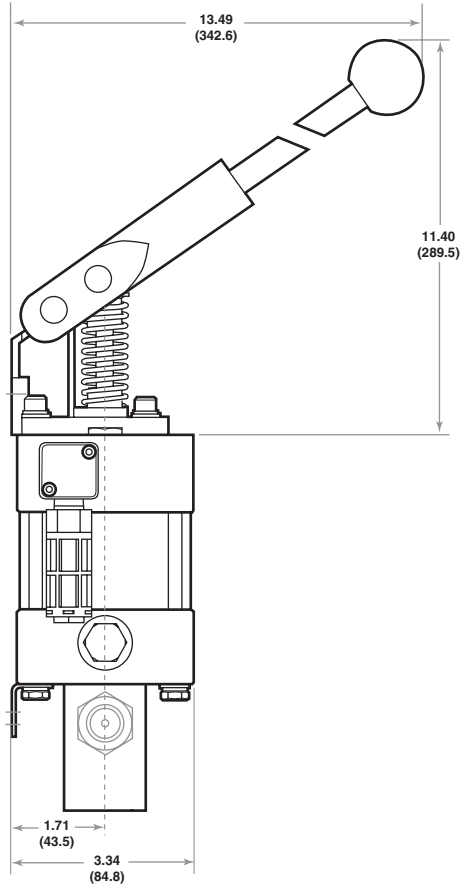

**Right View**

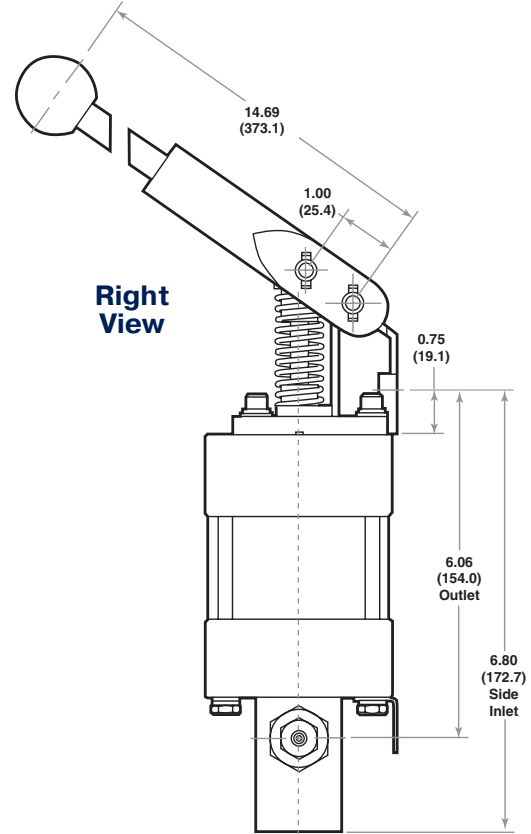

**Front View**

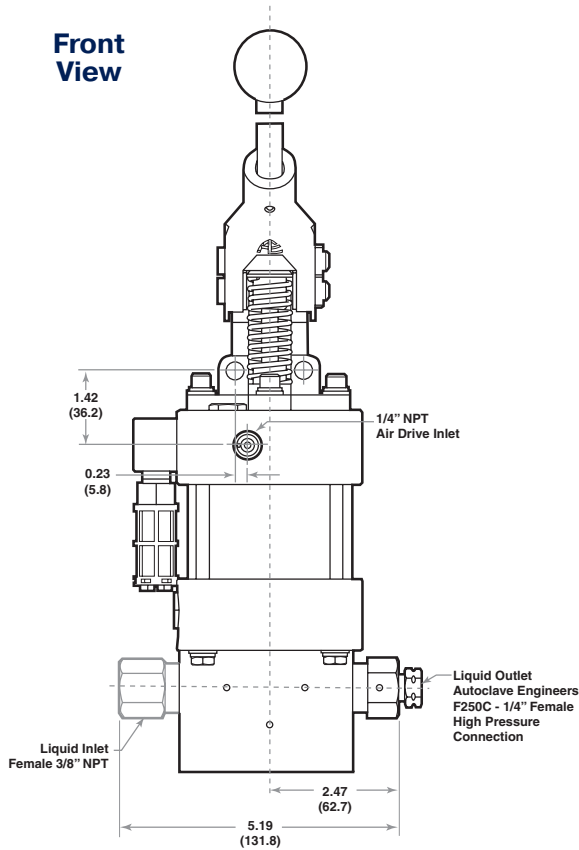

**Back View**

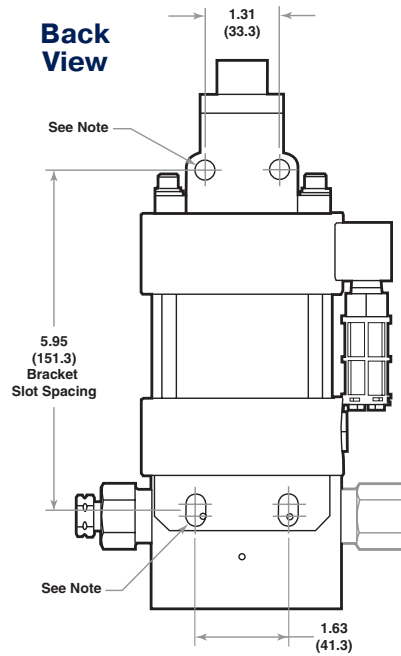

**Note:**

- Each Mounting Bracket includes (2) 11/32" (8.73) holes for 5/16" Bolts.
- Spool air tubing not shown for clarity.
- All dimensions are for reference only and are subject to change without notice.
- Primary Dimensions: Inches
- Secondary Dimensions: (Millimeters)

# AFL SERIES Double-Acting, Single Piston Air Drive

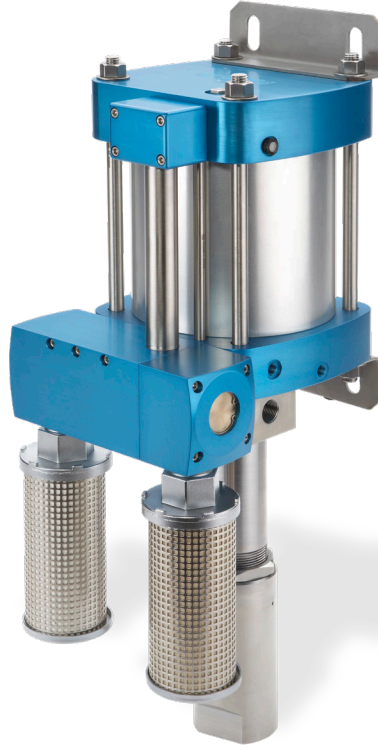

## Features:

- Pressure Ranges from 5,600 to 15,000 psi (385 to 1035 bar) max
- Operating Temperature Range: 0° to 140°F (-18° to 60°C)
- Pressure Head Material: 15-5 PH Stainless Steel
- Plunger: Stainless Steel, coated w/proprietary multi-layer carbon for long life
- Liquid Side Material: All Stainless-Steel Construction
- Air Side Material: Anodized Aluminum

## Technical Data:

- Liquid Connections: Bottom Inlet Only – see chart (page 17)
- Isolation Chamber: Standard on all sizes
- Displacement per stroke: See chart (page 17)
- Liquid Seals: UHMWPE U-Cup w/ optional o-rings (see P/N matrix)
- Air Drive Pressure Range: 15-150 psi (1-10 bar) \* See Note
- Main Air Inlet: 3/4" FNPT (Regulated)
- Pilot Air Inlet: 1/8" FNPT (unregulated)
- Exhaust Port (muffler removed) 1" FNPT
- Max Air Consumption: 167 SCFM @ 90 psi
- Pre-Lubricated Piston at Factory
- Air Seals: Buna-N

**Note:** \*Maximum air drive pressure is limited by maximum pressure shown in chart on Page 17.



## AFL Pump Part Number Matrix

Typical catalog number: **AFL60-1DBCVP**



Pump Type / Size / Ratio	Liquid Inlet Location	Isolation Chamber	Liquid Seal Materials
<b>AFL</b> = • High Flow, High Pressure Pump • 6" Single Piston Air Drive • Air-to-Liquid Pressure Ratio: AFL35-1D - 1:39 AFL60-1D - 1:70 AFL100-1D - 1:113	<b>B</b> = Bottom	<b>C</b> = Included	<b>PV</b> = UHMWPE U-Cup with FKM O-Rings <b>PB</b> = UHMWPE U-Cup with Buna N O-rings <b>PC</b> = UHMWPE U-Cup with FFKM O-rings

**Note:** Individual Pump Specifications can be found at [www.Autoclave.com](http://www.Autoclave.com).

## Reference Guide

Catalog Number	Pressure Ratio	Maximum Rated Outlet Pressure PSI (bar)	Displacement Per Cycle in <sup>3</sup> (cm <sup>3</sup> )	Liquid Connections	
				Inlet	Outlet
AFL35-1DBCXX	1:39	5,600 (386)	6.02 (98.7)	1" FNPT	9/16" SF562CX
AFL60-1DBCXX	1:70	10,000 (690)	3.40 (55.7)	1" FNPT	9/16" SF562CX
AFL100-1DBCXX	1:113	15,000 (1034)	2.30 (37.7)	1" FNPT	9/16" SF562CX

## Flow Rate Table: Air Drive Pressure (psi) vs. Outlet Pressure (psi)

Catalog Number	Air Drive Pressure (psi)	Outlet Pressure (psi)								Liters / min.
		0	500	1,500	3,000	4,500	6,000	10,000	15,000	
AFL35	60	24	19	9						
	90	25	21	16	6					
	120	26	23	19	12	2				
AFL60	60	14	12	9	4					
	90	14	13	11	8	6	1			
	120	15	14	12	10	8	6			
AFL100	60	10	9	7	5	3	1			
	90	11	10	8	7	6	5	1		
	120	12	11	9	8	7	6	3		

## Air Drive Connection

All AFL Series Pumps have a 1/2" FNPT regulated main air drive supply connection and utilize a 1/8" FNPT unregulated pilot port connection for remote start/stop operation. It is recommended to operate the pilot port at a higher air pressure than the main air drive supply pressure for proper function.

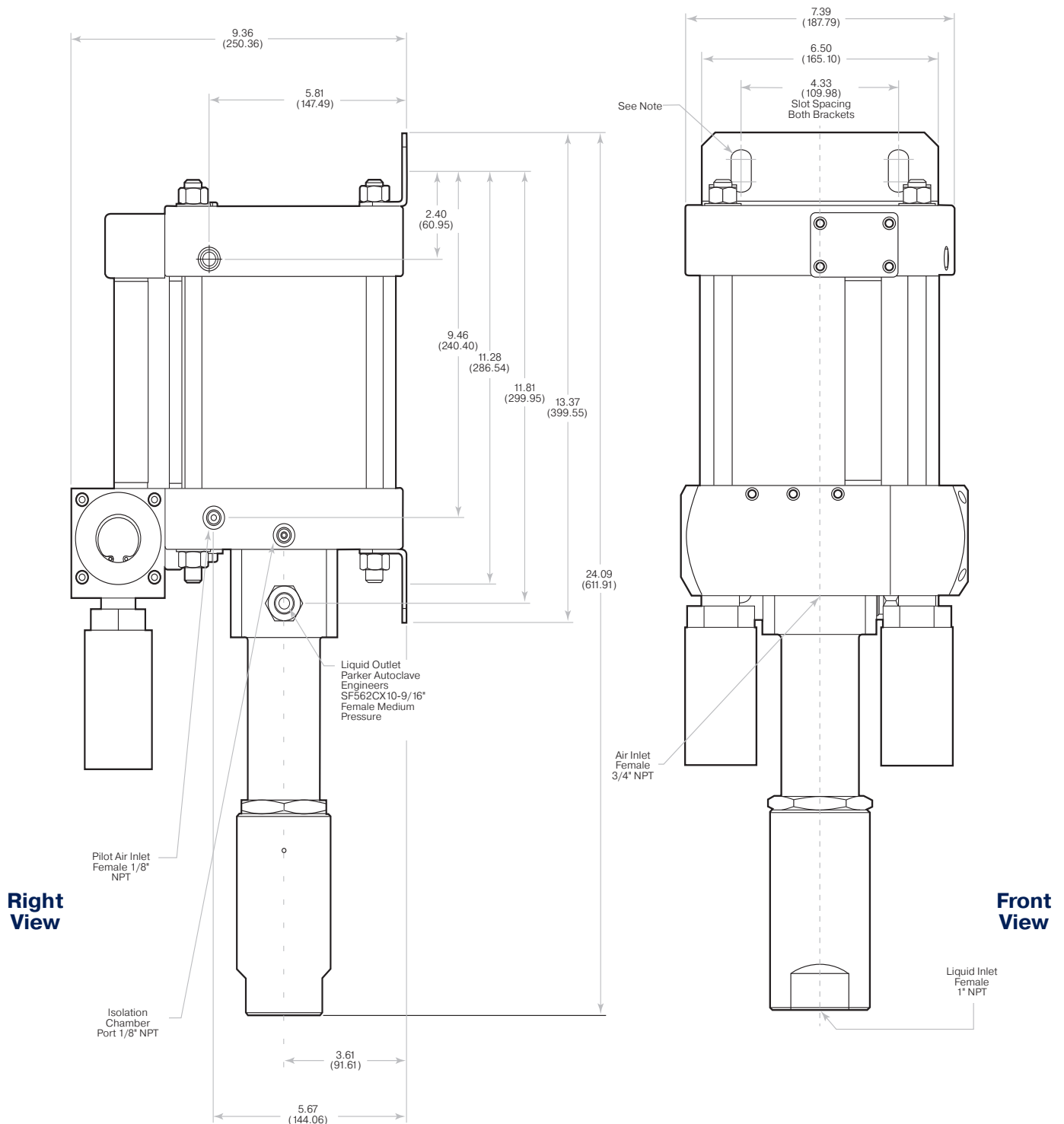

### Note:

- Each Mounting Bracket includes (2) 9/16" (14.29) holes for 1/2" Bolts.
- All dimensions are for reference only and are subject to change without notice.
- Primary Dimensions: Inches
- Secondary Dimensions: (Millimeters)

# AHL SERIES Double-Acting, Double Piston Air Drive

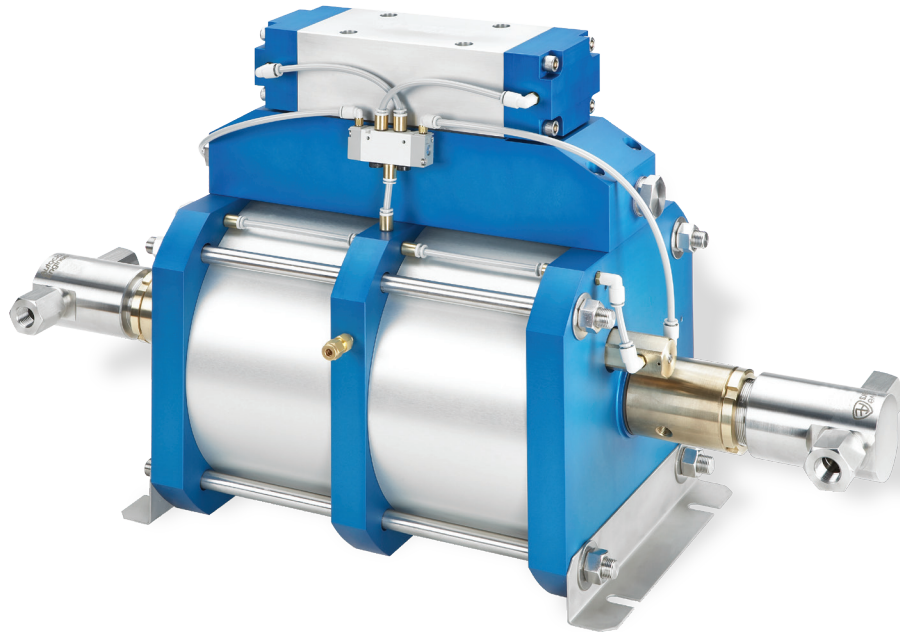

## Features:

- Pressure Ranges from 6,700 to 22,500 psi (460 to 1550 bar) max
- Operating Temperature Range: 0° to 140°F (-18° to 60°C)
- Pressure Head Material: 15-5 PH Stainless Steel
- Plunger: Stainless Steel, coated w/proprietary multi-layer carbon for long life
- Liquid Side Material: All Stainless-Steel Construction
- Air Side Material: Anodized Aluminum

## Technical Data:

- Liquid Connections: Dual Side Inlet Only – see chart (page 20)
- Isolation Chamber: Standard on all sizes
- Displacement per stroke: See chart (page 20)
- Liquid Seals: Thermoplastic Polyester U-Cup w/ optional o-rings (see P/N matrix)
- Air Drive Pressure Range: 20-100 psi (1.5-7 bar) \* See Note
- Main Air Inlet: 1" FNPT (Regulated)
- Pilot Air Inlet: 1/8" FNPT (unregulated)
- Exhaust Port (muffler removed) 1" BSP
- Max Air Consumption: 290 SCFM @ 50 psi (no pressure)
- Pre-Lubricated Piston at Factory
- Air Seals: Buna-N

**Note:** \*Maximum air drive pressure is limited by maximum pressure

# AHL Pump Part Number Matrix

Typical catalog number: **AHL66-2DSCTV**

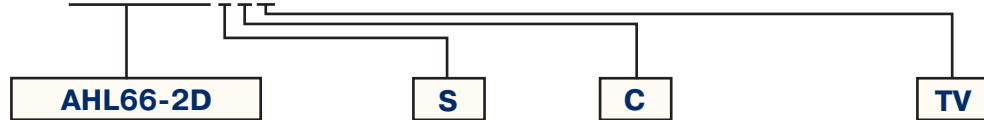

Pump Type / Size / Ratio	Liquid Inlet Location	Isolation Chamber	Liquid Seal Materials
<b>AHL</b> = <ul style="list-style-type: none"> <li>• High Flow, Liquid High Pressure Pump</li> <li>• 10" Dual Piston Air Drive</li> <li>• Air-to-Liquid Pressure Ratio:               <ul style="list-style-type: none"> <li>AHL33-2D - 1:67</li> <li>AFL66-2D - 1:133</li> <li>AFL118-2D - 1:239</li> </ul> </li> </ul>	<b>S</b> = Side	<b>C</b> = Included	<b>TV</b> = Thermoplastic Polyester U-Cup and FKM O-Rings <b>TB</b> = Thermoplastic Polyester U-Cup and Buna-N O-Rings <b>TC</b> = Thermoplastic Polyester U-Cup and Perfluoroelastomer FFKM O-Rings

**Note:** Individual Pump Specifications can be found at [www.Autoclave.com](http://www.Autoclave.com).

## Reference Guide

Catalog Number	Pressure Ratio	Maximum Rated Outlet Pressure PSI (bar)	Displacement Per Cycle .in <sup>3</sup> (cm <sup>3</sup> )	Liquid Connections	
				Inlet	Outlet
AHL33-2DSCXX	1:67	6,700 (462)	15.3 (250.7)	1" FNPT	1/2" FNPT
AHL66-2DSCXX	1:133	13,300 (917)	7.8 (127.8)	1/2" FNPT	1/2" FNPT
AHL118-2DSCXX	1:239	22,500 (1551)	4.4 (72.1)	1/2" FNPT	SF562CX

## Liquid Flow Rate vs. Outlet Pressure: AHL33-2DSC Series

Approximate Air Drive Pressure: 100 psi			
Pressure (PSI)	Pressure (bar)	Flow (gpm)	Flow (liter/min)
0	0	7.6* (see note 2)	28.8* (see note 2)
1000	69	6.1	23.0
2000	138	5.7	21.5
3000	207	4.9	18.4
4000	276	4.0	15.2
5000	345	3.2	12.3
6000	414	1.8	6.9

Nominal Liquid Pressure (Stalled)			
Air Drive Pressure		Liquid Pressure	
PSI	bar	PSI	bar
20	1.4	1340	92.4
30	2.1	2010	138.6
40	2.8	2680	184.8
50	3.4	3350	231.0
60	4.1	4020	277.2
70	4.8	4690	323.4
80	5.5	5360	369.6
90	6.2	6030	415.8
100	6.9	6700	461.9

## Liquid Flow Rate vs. Outlet Pressure: AHL66-2DSC Series

Approximate Air Drive Pressure: 100 psi			
Pressure (PSI)	Pressure (bar)	Flow (gpm)	Flow (liter/min)
0	0	3.6* (see note 2)	13.7* (see note 2)
1000	69	3.4	12.9
2000	138	3.1	12.0
3000	207	2.9	11.2
4000	276	2.7	10.3
5000	345	2.5	9.5
6000	414	2.3	8.7
7000	483	2.2	8.2
8000	552	2.0	7.7
9000	621	1.8	6.7
10000	690	1.5	5.7
11000	759	1.3	4.8
12000	828	1.0	3.9

Nominal Liquid Pressure (Stalled)			
Air Drive Pressure		Liquid Pressure	
PSI	bar	PSI	bar
20	1.4	2660	183.4
30	2.1	3990	275.2
40	2.8	5320	366.9
50	3.4	6650	458.6
60	4.1	7980	550.3
70	4.8	9310	642.1
80	5.5	10640	733.8
90	6.2	11970	825.5
100	6.9	13300	917.2

## Liquid Flow Rate vs. Outlet Pressure: AHL118-2DSC Series

Approximate Air Drive Pressure: 100 psi			
Pressure (PSI)	Pressure (bar)	Flow (gpm)	Flow (liter/min)
0	0	2.0	7.7
2000	138	1.8	6.9
4000	276	2.0	6.3
6000	414	1.5	5.8
8000	552	1.4	5.4
10000	689	1.3	5.1
12000	827	1.2	4.7
14000	965	1.1	4.3
16000	1103	1.0	3.8
18000	1241	0.8	3.1
20000	1379	0.6	2.3
22500	1551	0.2	0.8

Nominal Liquid Pressure (Stalled)			
Air Drive Pressure		Liquid Pressure	
PSI	bar	PSI	bar
20	1.4	4780	329.6
30	2.1	7170	494.4
40	2.8	9560	659.1
50	3.4	11950	823.9
60	4.1	14340	988.7
70	4.8	16730	1153.5
80	5.5	19120	1318.3
90	6.2	21510	1483.1
95	6.6	22500	1551.3

**Note:**

- Actual flow rates will vary depending on air flow capacity, downstream flow restrictions, and fluid type.
- Flow valve at approximately 50 psi air drive pressure.

## Air Drive Connection

All AHL series pumps have a 1" FNPT regulated main air drive supply connection and utilize a 1/8" FNPT unregulated pilot port connection for remote start/stop operation. It is recommended to operate the pilot port at a higher air pressure than the main air drive supply pressure for proper function.

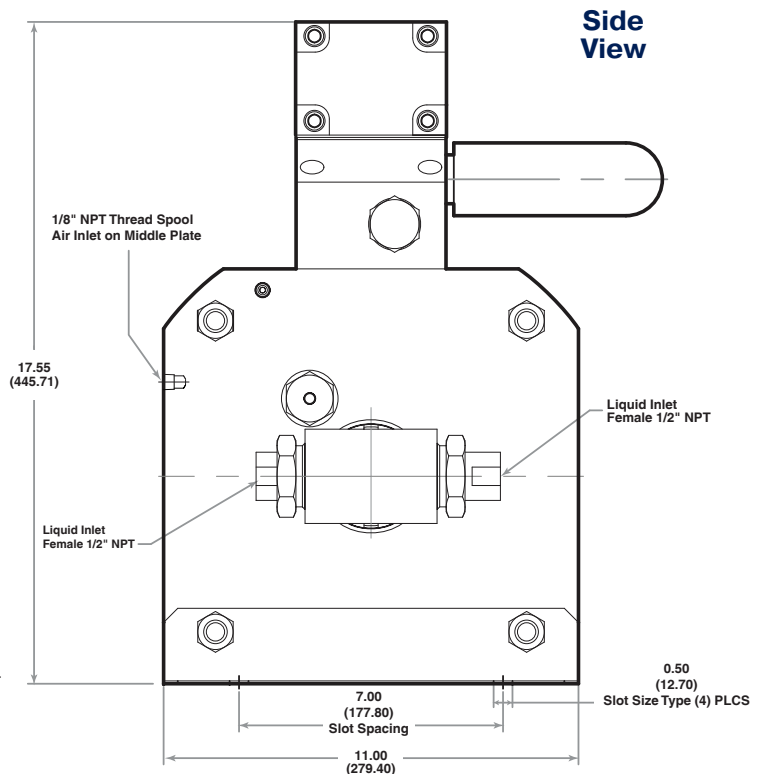
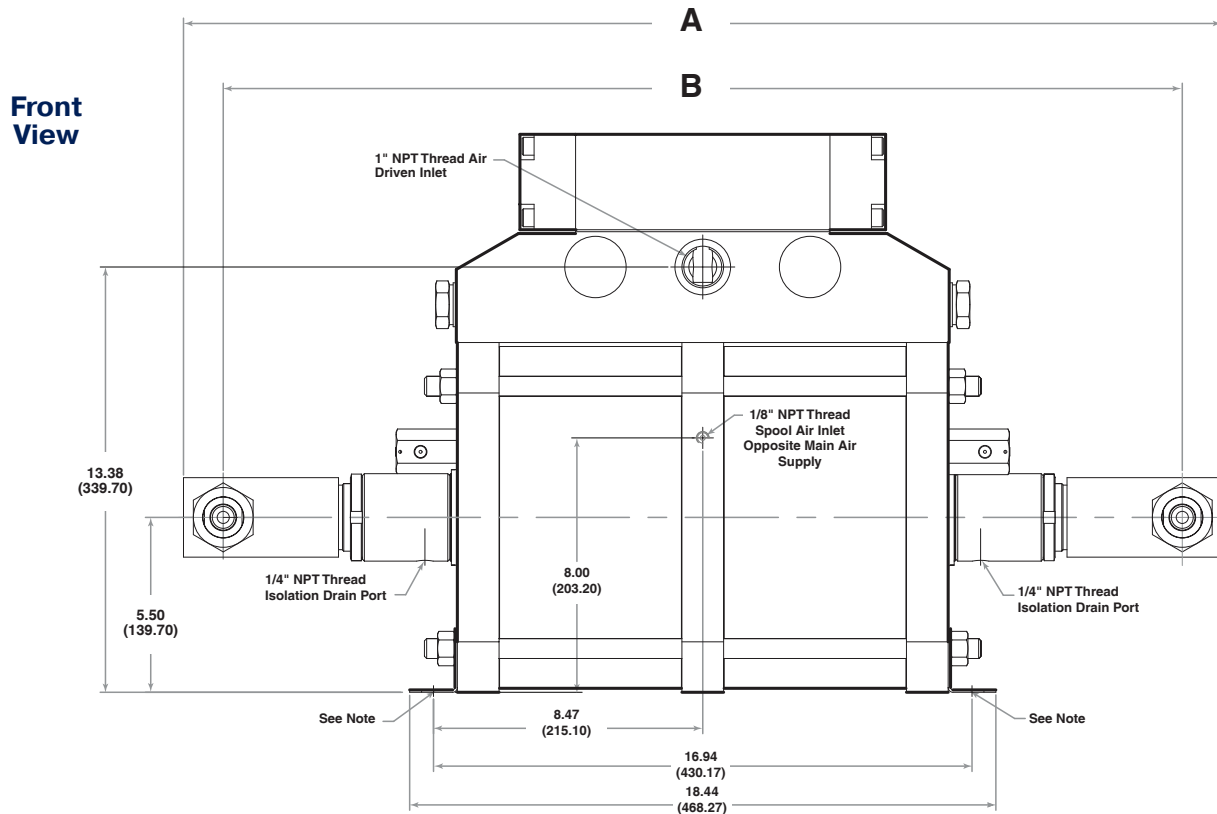

Model	A	B
AHL33	32.41 (823.21)	30.42 (772.41)
AHL66	32.66 (829.61)	30.16 (766.11)
AHL118	32.66 (829.61)	30.16 (766.11)

### Note:

- Each Mounting Bracket includes (2) 9/16" (14.29) holes for 1/2" Bolts.
- All dimensions are for reference only and are subject to change without notice.
- Primary Dimensions: Inches
- Secondary Dimensions: (Millimeters)

# Parker's Motion & Control Technologies

At Parker, we're guided by a relentless drive to help our customers become more productive and achieve higher levels of profitability by engineering the best systems for their requirements. It means looking at customer applications from many angles to find new ways to create value. Whatever the motion and control technology need, Parker has the experience, breadth of product and global reach to consistently deliver. No company knows more about motion and control technology than Parker. For further information call 1-800-C-Parker.

MARKET	KEY MARKETS		KEY PRODUCTS	
 <b>AEROSPACE</b>	Aircraft Engines Commercial Transports Military Aircraft Regional Transports	Business and General Aviation Land-Based Weapons Systems Missiles and Launch Vehicles Unmanned Aerial Vehicles	Flight Control Systems & Components Fluid Conveyance Systems Fluid Metering Delivery & Atomization Devices Fuel Systems & Components	Hydraulic Systems & Components Inert Nitrogen Generating Systems Pneumatic Systems & Components Wheels & Brakes
 <b>CLIMATE CONTROL</b>	Agriculture Food, Beverage and Dairy Precision Cooling Transportation	Air Conditioning Life Sciences & Medical Processing	Co2 Controls Electronic Controllers Filter Driers Hand Shut-Off Valves Hose & Fittings	Pressure Regulating Valves Refrigerant Distributors Safety Relief Valves Solenoid Valves Thermostatic Expansion Valves
 <b>ELECTRO-MECHANICAL</b>	Aerospace Life Science & Medical Packaging Machinery Plastics Machinery & Converting Semiconductor & Electronics Factory Automation	Machine Tools Paper Machinery Primary Metals Textile Wire & Cable	AC/DC Drives & Systems Electric Actuators, Gantry Robots & Slides Electrohydraulic Actuation Systems Electromechanical Actuation Systems Human Machine Interface	Linear Motors Stepper Motors, Servo Motors & Controls Structural Extrusions
 <b>FILTRATION</b>	Food & Beverage Life Sciences Mobile Equipment Power Generation Transportation	Industrial Machinery Marine Oil & Gas Process	Analytical Gas Generators Compressed Air & Gas Filters Condition Monitoring Engine Air, Fuel & Oil Filtration & Systems	Hydraulic, Lubrication & Coolant Filters Process, Chemical, Water Microfiltration Filters Nitrogen, Hydrogen & Zero Air Generators
 <b>FLUID and GAS HANDLING</b>	Aerospace Agriculture Bulk Chemical Handling Construction Machinery Food & Beverage Fuel & Gas Delivery	Industrial Machinery Mobile Oil & Gas Transportation Welding	Brass Fittings & Valves Diagnostic Equipment Fluid Conveyance Systems Industrial Hose	PTFE & PFA Hose, Tubing & Plastic Fittings Rubber & Thermoplastic Hose & Couplings Tube Fittings & Adapters Quick Disconnects
 <b>HYDRAULICS</b>	Aerospace Aerial lift Agriculture Construction Machinery Forestry	Industrial Machinery Mining Oil & Gas Power Generation & Energy Truck Hydraulics	Diagnostic Equipment Hydraulic Cylinders & Accumulators Hydraulic Motors & Pumps Hydraulic Systems Hydraulic Valves & Controls	Power Take-Offs Rubber & Thermoplastic Hose & Couplings Tube Fittings & Adapters Quick Disconnects
 <b>PNEUMATICS</b>	Aerospace Conveyor & Material Handling Factory Automation Life Science & Medical	Machine Tools Packaging Machinery Transportation & Automotive	Air Preparation Brass Fittings & Valves Manifolds Pneumatic Accessories Pneumatic Actuators & Grippers Pneumatic Valves & Controls	Quick Disconnects Rotary Actuators Rubber & Thermoplastic Hose & Couplings Structural Extrusions Thermoplastic Tubing & Fittings Vacuum Generators, Cups & Sensors
 <b>PROCESS CONTROL</b>	Chemical & Refining Food, Beverage & Dairy Medical & Dental	Microelectronics Oil & Gas Power Generation	Analytical Sample Conditioning Products & Systems Fluoropolymer Chemical Delivery Fittings, Valves & Pumps High Purity Gas Delivery Fittings, & Valves & Regulators	Instrumentation Fittings, Valves Regulators Medium Pressure Fittings & Valves Process Control Manifolds
 <b>SEALING and SHIELDING</b>	Aerospace Chemical Processing Consumer Energy, Oil & Gas Fluid Power General Industrial	Information Technology Life Sciences Military Semiconductor Transportation	Dynamic Seals Elastomeric O-Rings Emi Shielding Extruded & Precision-Cut, Fabricated Elastomeric Seals	Homogeneous & Inserted Elastomeric Shapes High Temperature Metal Seals Metal & Plastic Retained Composite Seals Thermal Management

# Parker Worldwide

## North America

**USA** – Corporate, Cleveland, OH  
Tel: +1 256 896 3000

**USA** – IPD, Huntsville, AL  
Tel: +1 256 881 2040  
ipdcct@parker.com

**USA** – IPD, (Autoclave), Erie, PA  
Tel: +1 814 860 5700  
ipdaecc@parker.com

**CA** – Canada, Grimsby, Ontario  
Tel: +1 905-945-2274  
ipd\_canada@parker.com

## South America

**AR** – Argentina, Buenos Aires  
Tel: +54 3327 44 4129  
falecom@parker.com

**BR** – Brazil, Diadema, SP  
Diadema, SP  
Tel: +55 11 4360 6700  
falecom@parker.com

**CL** – Chile, Santiago  
Tel: +56 (0) 2 2303 9640  
falecom@parker.com

**MX** – Mexico, Toluca  
Tel: +52 722 275 4200  
contacto@parker.com

## Asia Pacific

**AU** – Australia, Dandenong  
Tel: +61 (0)2 9842 5150  
customer.service.au@parker.com

**CN** – China, Shanghai  
Tel: +86 21 2899 5000  
INGtechnical.china@parker.com

**HK** – Hong Kong  
Tel: +852 2428 8008

**IN** – India, Mumbai  
Tel: +91 22 6513 7081-85

**ID** – Indonesia, Tangerang  
Tel: +62 2977 7900  
parker.id@parker.com

**JP** – Japan, Tokyo  
Tel: +(81) 3 6365 4020  
infophj@parker.com

**KR** – South Korea, Seoul  
Tel: +82 2 559 0400  
parkerkr@parker.com

**MY** – Malaysia, Selangor  
Tel: +603 784 90 800  
parkermy@parker.com

**SG** – Singapore,  
Tel: +65 6887 6300  
parkersg@parker.com

**TH** – Thailand, Bangkok  
Tel: +66 2 186 7000  
phthailand@parker.com

**TW** – Taiwan, Taipei  
Tel: +886 2 2298 8987  
enquiry.taiwan@parker.com

**VN** – Vietnam, Hochi Minh City  
Tel: +848 382 508 56  
parker\_viet@parker.com

## Europe, Middle East, Africa

**AE** – UAE, Dubai  
Tel: +971 4 812 7100  
parker.me@parker.com

**AT** – Austria, Wiener Neustadt  
Tel: +43 (0)2622 23501-0  
parker.austria@parker.com

**AT** – Eastern Europe, Wiener Neustadt  
Tel: +43 (0)2622 23501 900  
parker.easteurope@parker.com

**AZ** – Azerbaijan, Baku  
Tel: +994 50 2233 458  
parker.azerbaijan@parker.com

**BE/LU** – Belgium, Nivelles  
Tel: +32 (0)67 280 900  
parker.belgium@parker.com

**BG** – Bulgaria, Sofia  
Tel: +359 2 980 1344  
parker.bulgaria@parker.com

**BY** – Belarus, Minsk  
Tel: +48 (0)22 573 24 00  
parker.belarus@parker.com

**CH** – Switzerland, Etoy  
Tel: +41 (0) 21 821 87 00  
parker.switzerland@parker.com

**CZ** – Czech Republic, Klecany  
Tel: +420 284 083 111  
parker.czechrepublic@parker.com

**DE** – Germany, Kaarst  
Tel: +49 (0)2131 4016 0  
parker.germany@parker.com

**DK** – Denmark, Ballerup  
Tel: +45 43 56 04 00  
parker.denmark@parker.com

**ES** – Spain, Madrid  
Tel: +34 902 33 00 01  
parker.spain@parker.com

**FI** – Finland, Vantaa  
Tel: +358 (0)20 753 2500  
parker.finland@parker.com

**FR** – France, Contamine s/Rive  
Tel: +33 (0)4 50 25 80 25  
parker.france@parker.com

**GR** – Greece, Athens  
Tel: +30 210 933 6450  
parker.greece@parker.com

**HU** – Hungary, Budapest  
Tel: +36 223 885 470  
parker.hungary@parker.com

**IE** – Ireland, Dublin  
Tel: +353 (0)1 466 6370  
parker.ireland@parker.com

**IT** – Italy, Corsico (MI)  
Tel: +39 02 45 19 21  
parker.italy@parker.com

**KZ** – Kazakhstan, Almaty  
Tel: +7 7273 561 000  
parker.easteurope@parker.com

**NL** – The Netherlands, Oldenzaal  
Tel: +31 (0)541 585 000  
parker.nl@parker.com

**NO** – Norway, Stavanger  
Tel: +47 66 75 34 00  
parker.norway@parker.com

**PL** – Poland, Warsaw  
Tel: +48 (0)22 573 24 00  
parker.poland@parker.com

**PT** – Portugal, Leca da Palmeira  
Tel: +351 22 999 7360  
parker.portugal@parker.com

**RO** – Romania, Bucharest  
Tel: +40 21 252 1382  
parker.romania@parker.com

**RU** – Russia, Moscow  
Tel: +7 495 645-2156  
parker.russia@parker.com

**SE** – Sweden, Spånga  
Tel: +46 (0)8 59 79 50 00  
parker.sweden@parker.com

**SK** – Slovakia, Banská Bystrica  
Tel: +421 484 162 252  
parker.slovakia@parker.com

**SL** – Slovenia, Novo Mesto  
Tel: +386 7 337 6650  
parker.slovenia@parker.com

**TR** – Turkey, Istanbul  
Tel: +90 216 4997081  
parker.turkey@parker.com

**UA** – Ukraine, Kiev  
Tel: +48 (0)22 573 24 00  
parker.ukraine@parker.com

**UK** – United Kingdom, Warwick  
Tel: +44 (0)1926 317 878  
parker.uk@parker.com

**ZA** – South Africa, Kempton Park  
Tel: +27 (0)11 961 0700  
parker.southafrica@parker.com

## ! CAUTION !

Do not mix or interchange component parts or tubing with those of other manufacturers. Doing so is unsafe and will void warranty.

Parker Autoclave Engineers Valves, Fittings, and Tools are not designed to interface with common commercial instrument tubing and are designed to only connect with tubing manufactured to Parker Autoclave Engineers AES specifications. Failure to do so is unsafe and will void warranty.

## WARNING

**FAILURE, IMPROPER SELECTION OR IMPROPER USE OF THE PRODUCTS AND/OR SYSTEMS DESCRIBED HEREIN OR RELATED ITEMS CAN CAUSE DEATH, PERSONAL INJURY AND PROPERTY DAMAGE.**

This document and other information from Parker Hannifin Corporation, its subsidiaries and authorized distributors provide product and/or system options for further investigation by users having technical expertise. It is important that you analyze all aspects of your application and review the information concerning the product or system in the current product catalog. Due to the variety of operating conditions and applications for these products or systems, the user, through its own analysis and testing, is solely responsible for making the final selection of the products and systems and assuring that all performance, safety and warning requirements of the application are met. The products described herein, including without limitation, product features, specifications, designs, availability and pricing, are subject to change by Parker Hannifin Corporation and its subsidiaries at any time without notice.

## Offer of Sale

The items described in this document are available for sale by Parker Hannifin Corporation, its subsidiaries or its authorized distributors. Any sale contract entered by Parker will be governed by the provisions stated in Parker's standard terms and conditions of sale (copy available upon request).



Instrumentation Products Division  
Autoclave Engineers Operation  
8325 Hessinger Drive  
Erie, PA 16509-4679  
Tel: 814 860 5700  
Fax: 814 860 5811  
[www.autoclave.com](http://www.autoclave.com)

Instrumentation Products Division Headquarters  
1005 A Cleaner Way  
Huntsville, AL 35805 USA  
Tel: 256 881 2040  
Fax: 256 881 5072  
[www.parker.com/ipd](http://www.parker.com/ipd)

Parker Hannifin Manufacturing Ltd.  
Instrumentation Products Division,  
Europe  
Riverside Road  
Pottington Business Park  
Barnstaple, UK, EX31 1NP, UK  
Tel: 44 1271 313131  
Fax: 44 1271 373636